

Dispense head VTOE



Dispense head VTOE

Key features

Description

The dispense head VTOE is available in two different variants:

- With transparent channel plate made from polycarbonate (PC)
- With a media-resistant channel plate made from polyether ether ketone (PEEK)

Both variants offer three different dosing syringes with three different internal diameters as standard.

Advantages:

- Ready-to-install dosing solution saves time and costs
- Compact 9 mm grid dimension
- Maximum dosing precision down to the microlitre range
- Ideally suited to contactless dispensing and jetting of liquid media
- Dosing valve isolated from the media, for sensitive and aggressive liquid media
- Small internal volume makes it easy to rinse

Design VTOE-...-S

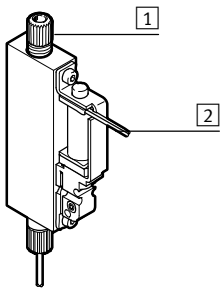

- 1 Fluid connector
- 2 Individual electrical connection

Single-channel dispense head: enables dosing with the utmost precision.

Typical areas of application:

- Producing dilutions
- Adding nutrient solutions
- Dosing reagents

Design VTOE-8-...-M

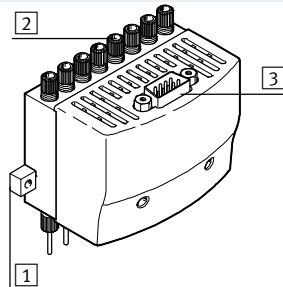

- 1 Mounting rail
- 2 Fluid connectors
- 3 Electrical multi-pin plug connection

8-channel dispense head: The system is optimally designed for microplates and enables a very high throughput as well as dosing of various fill quantities and liquid media. Individual control of the valves permits the channels to be coordinated for maximum precision.

Typical areas of application:

- Preparing samples
- Adding liquid media to microplates

Range of applications

The dispense head VTOE is intended for use in dispensing liquid media into various vessels, especially microplates. The dispense head is designed for precisely dispensing the smallest amount of liquids, especially in applications in

laboratory automation, analysis technology and in-vitro diagnostics. The media typically include reagents, cell culture media, buffer solutions and (prepared) samples.

Dosing is generally carried out contactlessly, i.e. a drop or jet is released from the dosing syringe without making contact with the destination vessel.

The intended target volume, precision and accuracy are primarily configured by the correct regulation of the working pressure and opening times of the dosing valves.

Assembly

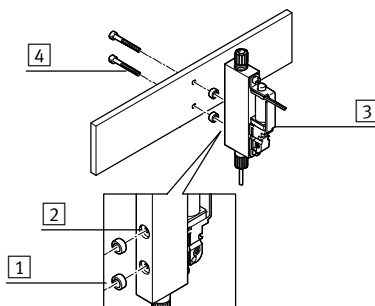

- 1 Centring rings
- 2 Holes
- 3 Dispense head
- 4 Screws

Position the centring rings in the holes and mount the dispense head on the rail using the screws.

Up to eight dispense heads can be mounted on one rail, with a grid dimension of 9 mm.

Dispense head VTOE

Product range overview

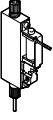
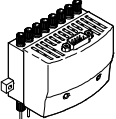
Function	Description	Nominal width dosing needle	Operating pressure	Operating voltage
		[mm]	[bar]	
Single-channel dispense head 	2/2-way valve, normally closed, single solenoid Electrical connection, cable, open end	0.32	0 ... 0.5	24 V DC
		0.6	0 ... 0.5	24 V DC
		1.0	0 ... 0.5	24 V DC
8-channel dispense head 	8x 2/2-way valves, normally closed, single solenoid Electrical connection, Sub-D, 9-pin	0.32	0 ... 0.5	24 V DC
		0.6	0 ... 0.5	24 V DC
		1.0	0 ... 0.5	24 V DC

Dispense head VTOE

Type codes

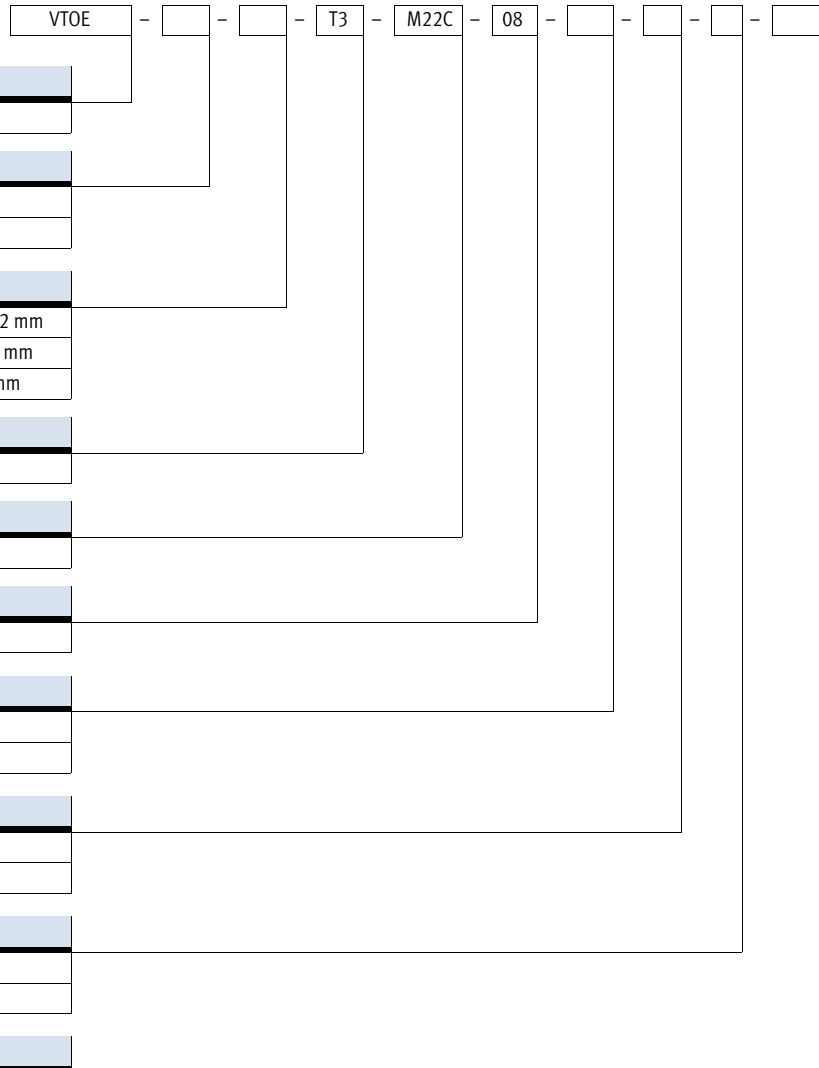

Type

VTOE	Dispense head
------	---------------

Valve position

-	1 valve position
8	8 valve positions

Output connection

D7	Nozzle, length 30 mm, nominal width 0.32 mm
D8	Nozzle, length 30 mm, nominal width 0.6 mm
D9	Nozzle, length 30 mm, nominal width 1 mm

Input connection

T3	For tubing with outside diameter 3 mm
----	---------------------------------------

Valve function

M22C	2/2-way valve, normally closed
------	--------------------------------

Nominal width

08	0.8 mm
----	--------

Diaphragm and sealing materials

F	Perfluoroelastomer
V	Fluoroelastomer

Material housing

P	Polyether ether ketone
S	Polyphenylene sulphide

Manifold block material



P	Polyether ether ketone
PC	Polycarbonate

Valve control

M	Electrical multi-pin plug connection
S	Individual electrical connection

Dispense head VTOE

Technical data

-  Voltage
24 V DC
-  Operating pressure
0 ... 0.5 bar

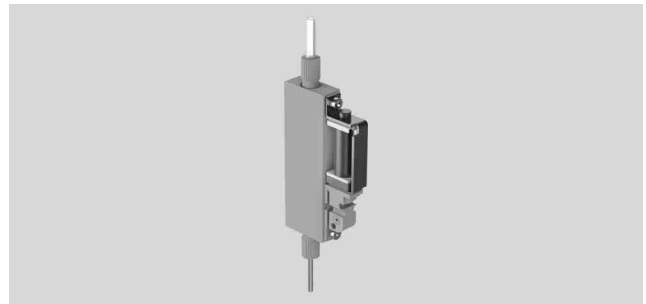

General technical data			
Type		VTOE-...-S	VTOE-8-...-M
Valve function		2/2-way valve, closed, single solenoid	
Type of reset		Mechanical spring	
Nominal width of dosing needle	VTOE-...-D7	[mm] 0.32	0.32
	VTOE-...-D8	[mm] 0.6	0.6
	VTOE-...-D9	[mm] 1	1
Grid dimension	[mm]	9	
Fluid connector		UNF1/4-28	8x UNF1/4-28
Note on fluid connector		Fitting for tubing with 3 mm outside diameter enclosed	
Electrical connection			
Connection technology		Cable, open end, 2-wire	Sub-D plug connector, 9-pin
Cable length		0.15	-
Wire ends		Sheath removed	-
Nominal conductor cross section		AWG28	-
Type of actuation		Electrical	
Type of control		Direct	
Sealing principle		Soft	
Type of mounting		Via female thread M2 and centring sleeve	Via female thread and centring sleeve
		-	Via through-hole for M3 screw
Mounting position		Any	
Product weight	[g]	18	220

Electrical data		
Nominal operating voltage	[V DC]	24
Permissible voltage fluctuations	[%]	±10
Max. electrical power consumption	[W]	1.8 (per valve)
Duty cycle	[%]	100
Degree of protection		IP30 (completely mounted)

Dispense head VTOE

Technical data

Operating and environmental conditions		
Operating pressure	[bar]	0 ... 0.5
Operating medium		Gaseous media
		Liquid media
Note on the operating/pilot medium		Observe durability of materials that come into contact with the media
Ambient temperature	[°C]	5 ... 40
Temperature of medium	[°C]	5 ... 50
Storage temperature	[°C]	5 ... 40
Corrosion resistance class CRC		0 ¹⁾

1) Corrosion resistance class CRC 0 to Festo standard FN 940070
 No corrosion stress. Applies to small, visually unimportant standard parts such as threaded pins, circlips, clamping sleeves etc. that are generally only available on the market in a phosphated or burnished version (oiled if applicable), as well as to ball bearings (for components $\lt; \Phi 0 > \text{ XPX3}$) *ανδ πλαν βεαρμνγσ.*

Materials		
Dosing needle		High-alloy stainless steel
Note on materials		RoHS-compliant
		Contains paint-wetting impairment substances
Materials in contact with the medium	VTOE-...-V-S-PC	ETFE, PEEK, PC, PPS, FPM, high-alloy stainless steel
	VTOE-...-F-P-P	ETFE, PEEK, FFPM, high-alloy stainless steel
Material number for dosing needle		1.4301

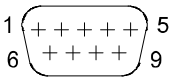
Pin allocation		
	Pin	Function
	1	Valve 1
	2	Valve 2
	...	
	8	Valve 8
	9	GND

Dispense head VTOE

Technical data

Dimensions

Download CAD data → www.festo.com

VTOE-...-S

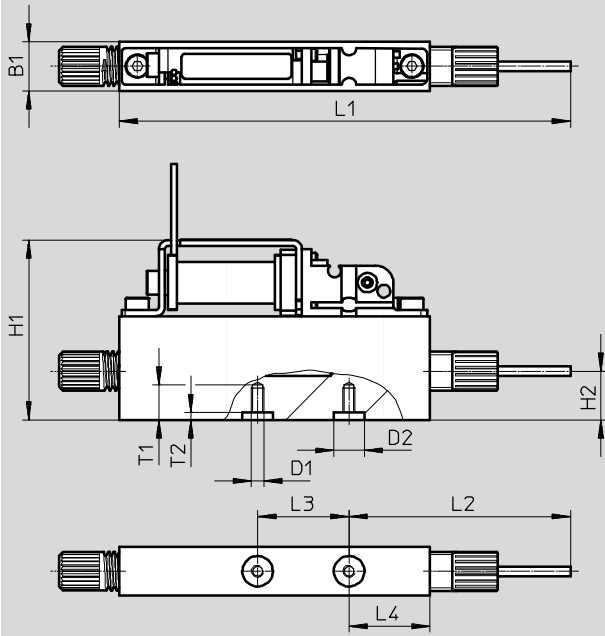

Type	B1	D1	D2 ∅	H1	H2	L1	L2	L3	L4	T1	T2
VTOE-...-S	8.1	M2	5	30	8	74	36.3	15	13.3	5.2	1.2

Dispense head VTOE

Technical data

Dimensions

Download CAD data → www.festo.com

VTOE-8-...-M

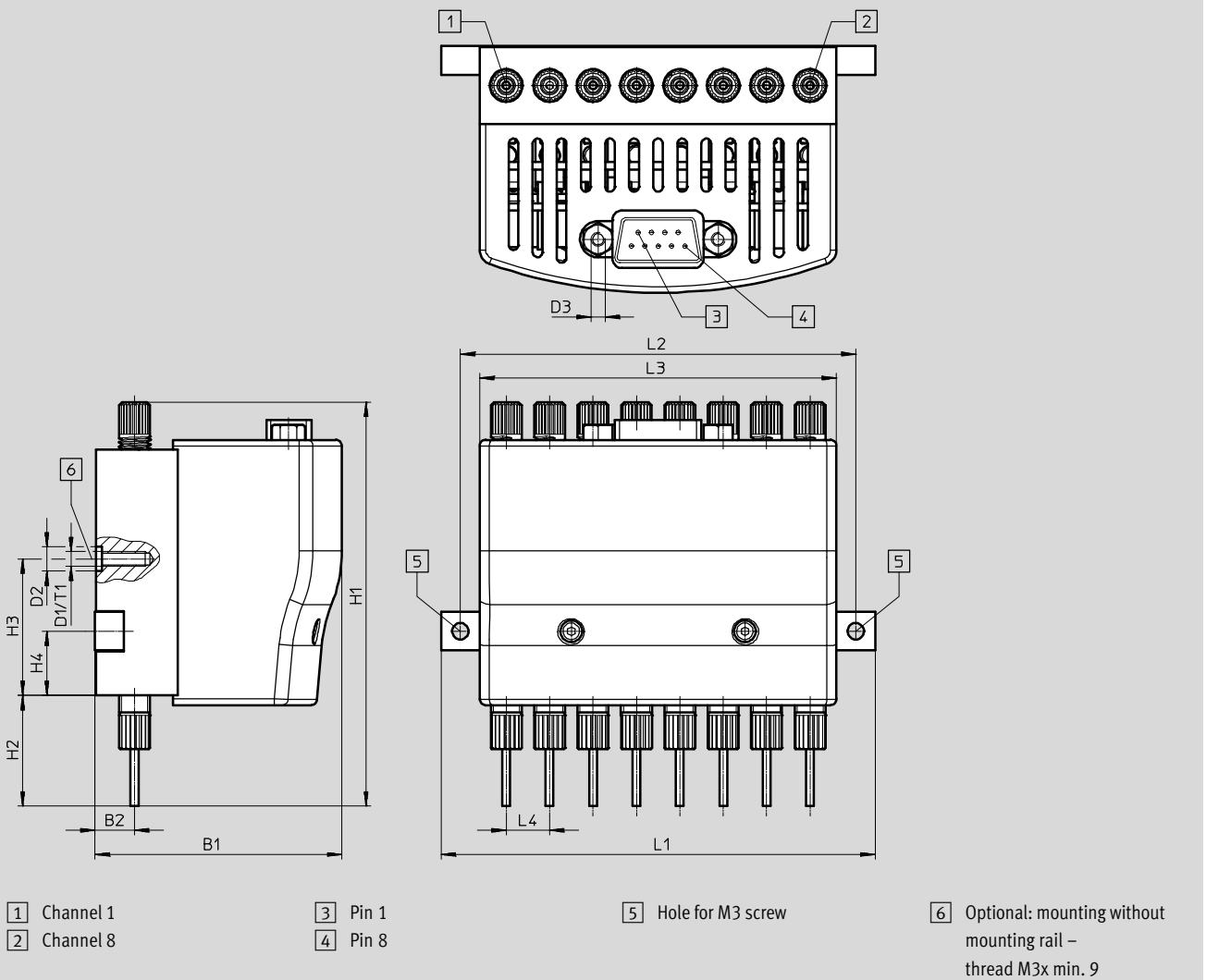



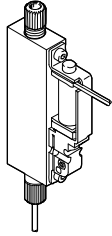
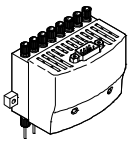

Type	B1	B2	D1 ∅	D2 ∅	D3 ∅	H1 ±2	H2	H3	H4	L1	L2	L3	L4	T1
VTOE-8-...-M	51.2	8.2	M3	5	UNC 4-40	84	23	28.3	13.3	90	82	74	9	10.2

Dispense head VTOE

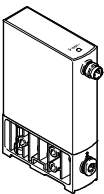
Accessories

Ordering data				
	Description	Nominal width dosing needle [mm]	Part No.	Type
Dispense head, individual connection				
	2/2-way valve, normally closed	0.32	8063372	VTOE-D7-T3-M22C-08-F-P-P-S
			8063369	VTOE-D7-T3-M22C-08-V-S-PC-S
		0.6	8063373	VTOE-D8-T3-M22C-08-F-P-P-S
			8063370	VTOE-D8-T3-M22C-08-V-S-PC-S
		1	8063374	VTOE-D9-T3-M22C-08-F-P-P-S
			8063371	VTOE-D9-T3-M22C-08-V-S-PC-S
Dispense head, 8-channel				
	8x 2/2-way valve, normally closed	0.32	8063637	VTOE-8-D7-T3-M22C-08-F-P-P-M
			8063634	VTOE-8-D7-T3-M22C-08-V-S-PC-M
		0.6	8063638	VTOE-8-D8-T3-M22C-08-F-P-P-M
			8063635	VTOE-8-D8-T3-M22C-08-V-S-PC-M
		1	8063639	VTOE-8-D9-T3-M22C-08-F-P-P-M
			8063636	VTOE-8-D9-T3-M22C-08-V-S-PC-M

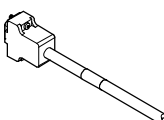
Ordering data				
		Pressure regulation range [bar]	Part No.	Type
In-line valve				
	Current type, 4 ... 20 mA	0.005 ... 1	8046304	VEAB-L-26-D7-Q4-A4-1R1
		0.001 ... 0.2	8046302	VEAB-L-26-D12-Q4-A4-1R1
	Voltage type, 0 ... 10 V	0.005 ... 1	8046303	VEAB-L-26-D7-Q4-V1-1R1
		0.001 ... 0.2	8046301	VEAB-L-26-D12-Q4-V1-1R1
Precision pressure regulator				
	For closed-loop control of the operating pressure	0.05 ... 0.7	159500	LRP-1/4-0,7
Pressure sensor				
	For monitoring compressed air and non-corrosive gases		8035542	SPAN-B2R-Q4-PNLK-PNVBA-L1
Plastic tubing				
	-		159660	PUN-3X0,5-BL
Connecting cable				
	Sub-D socket, 9-pin	2.5 m	531184	KMP6-09P-8-2,5
		5 m	531185	KMP6-09P-8-5
		10 m	531186	KMP6-09P-8-10

Festo North America

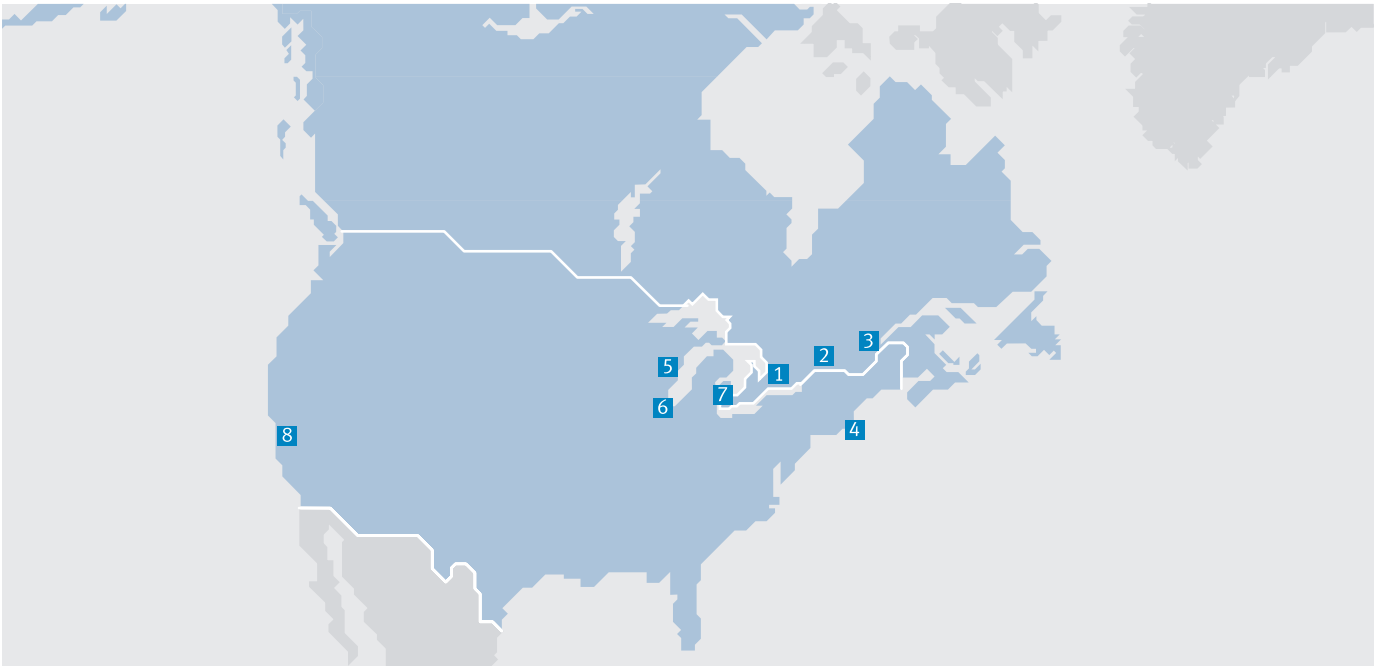

**1 Festo Canada
Headquarters
Festo Inc.**
5300 Explorer Drive
Mississauga, ON
L4W 5G4

2 Montréal
5600, Trans-Canada
Pointe-Claire, QC
H9R 1B6

3 Québec City
2930, rue Watt#117
Québec, QC
G1X 4G3



**4 Festo United States
Headquarters
Festo Corporation**
395 Moreland Road
Hauppauge, NY
11788

5 Appleton
North 922 Tower View Drive, Suite N
Greenville, WI
54942

7 Detroit
1441 West Long Lake Road
Troy, MI
48098

6 Chicago
85 W Algonquin - Suite 340
Arlington Heights, IL
60005

8 Silicon Valley
4935 Southfront Road, Suite F
Livermore, CA
94550

Festo Regional Contact Center

Canadian Customers

Commercial Support:
Tel: 1 877 GO FESTO (1 877 463 3786)
Fax: 1 877 FX FESTO (1 877 393 3786)
Email: festo.canada@ca.festo.com

Technical Support:
Tel: 1 866 GO FESTO (1 866 463 3786)
Fax: 1 877 FX FESTO (1 877 393 3786)
Email: technical.support@ca.festo.com

USA Customers

Commercial Support:
Tel: 1 800 99 FESTO (1 800 993 3786)
Fax: 1 800 96 FESTO (1 800 963 3786)
Email: customer.service@us.festo.com

Technical Support:
Tel: 1 866 GO FESTO (1 866 463 3786)
Fax: 1 800 96 FESTO (1 800 963 3786)
Email: product.support@us.festo.com