

Feed separators HPV



# Feed separators HPV

Key features at a glance

## Separation of workpieces in the supply process

### Previously

- Required at least 2 drives, 2 valves and 4 proximity sensors
- Extensive programming required

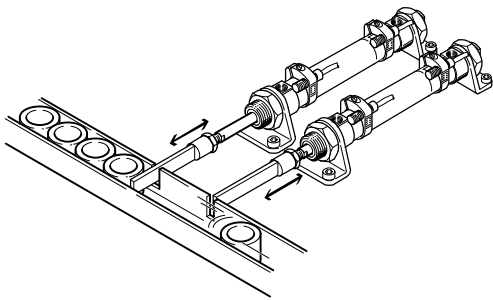

### Today

- One unit (1 drive, 1 valve and 2 proximity sensors)
- More cost-effective
- Reliable
- No programming required

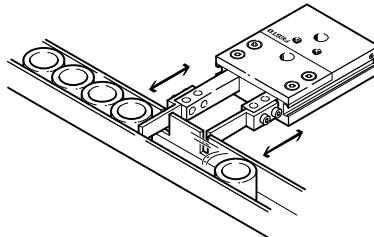

## High functionality

- 1 Corrosion-resistant thanks to stainless steel plungers
- 2 Optimum, accurate combination options with centring sleeves
- 3 Supply ports optionally at top or rear
- 4 Supports proximity sensors that can be integrated in the housing (SME/SMT-8)

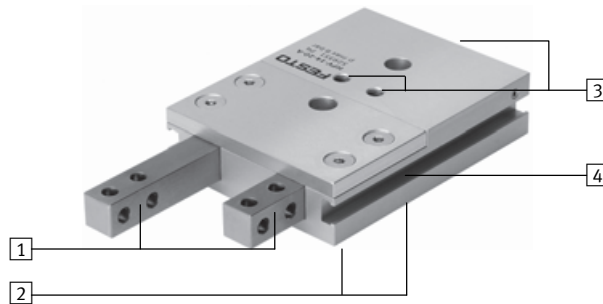

 Note

An integrated mechanical locking mechanism between the two plungers ensures that one piston cannot retract until the other has advanced. Both plungers are briefly extended upon changeover and the part to be separated is surrounded.

## Function principle

Plunger A is retracted. The locking mechanism locks plunger B.

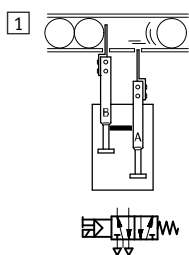

Plunger A advances.

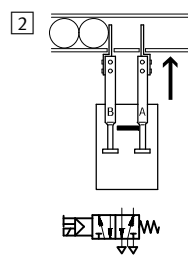

Plunger B cannot retract from the locking mechanism until plunger A is fully advanced.

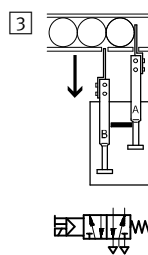

Plunger B advances.

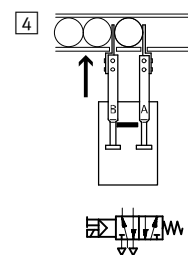

Plunger A cannot retract from the locking mechanism until plunger B is fully advanced.

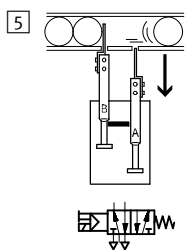

# Feed separators HPV

Peripherals overview and type codes

## Peripherals overview

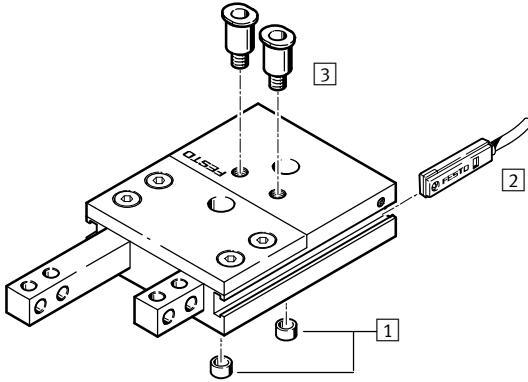

Accessories			
	Description	→ Page/Internet	
1	Centring sleeve, connecting sleeve	For centring when mounting	9
2	Proximity sensor	For position sensing, sensor is integrated in sensor slot	9
3	QS push-in fitting	For connecting compressed air tubing with standard external diameter	qs

## Type codes

		HPV	–	14	–	20	–	A
<b>Type</b>								
Double-acting								
HPV	Feed separator							
<b>Size [mm]</b>								
<b>Stroke [mm]</b>								
<b>Position sensing</b>								
A	Via proximity sensor							

# Feed separators HPV

Technical data

FESTO

Function

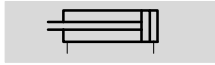

- Ø - Size  
10 ... 22

- l - Stroke length  
20 ... 60 mm

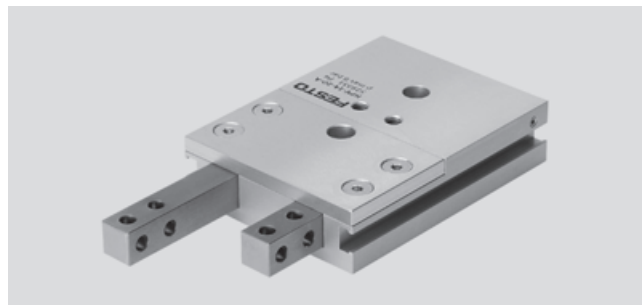

General technical data		10	14	22
Size		10	14	22
Pneumatic connection		M5/M3	M5/M5	
Mode of operation		Double-acting		
Operating medium		Compressed air in accordance with ISO 8573-1:2010 [7:4:4]		
Note on operating/pilot medium		Operation with lubricated medium possible (in which case lubricated operation will always be required)		
Design		Twin piston		
		Piston rod		
		Locking mechanism		
		Non-rotating		
Protection against torsion/guide		Square plungers		
Max. interchangeability [mm]		0.3		
Cushioning		None		
Position sensing		Via proximity sensor		
Type of mounting		Via through-holes		
		Via female thread		
Mounting position		Any		

Operating and environmental conditions		
Operating pressure [bar]		3 ... 8
Ambient temperature [°C]		+5 ... +60
Protection class		IP40
Corrosion resistance class CRC <sup>1)</sup>		2

1) Corrosion resistance class 2 to Festo standard 940 070

Components subject to moderate corrosion stress. Externally visible parts with primarily decorative surface requirements which are in direct contact with a normal industrial environment or media such as coolants or lubricating agents.

Forces [N]		10	14	22
Theoretical force at 6 bar		45	90	225
Advancing				
Theoretical force at 6 bar		35	75	180
Retracting				

Weights [g]		10	14	22		
Size		10	14	22		
Stroke		10	20	40	30	60
Product weight		135	290	460	950	1,500

# Feed separators HPV

Technical data

## Materials

Sectional view

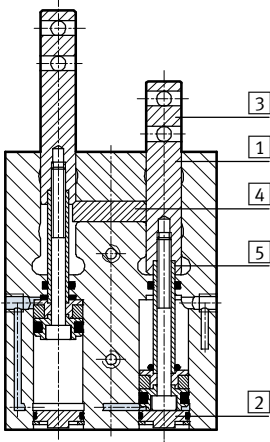

Feed separator

1	Body	Wrought aluminium alloy (with CompCoat)
2	End cover	High-alloy steel
3	Plunger	High-alloy steel
4	Locking mechanism	Case-hardened steel
5	Piston rod	High-alloy steel
-	Seals	Nitrile rubber
Note on materials		Copper and PTFE
		Conforms to RoHS

- Note

The plunger slideways in the housing are determined by the appropriate fit selected and cannot be adjusted. The

necessary basic lubrication is performed during assembly. We recommend that the feed separator

be re-lubricated after 2 million cycles.

## Cycle times [ms] without add-on plunger separators at 6 bar (unrestricted)

Half the cycle time:

Number 1 ... 3

Cycle time:

Number 1 ... 5

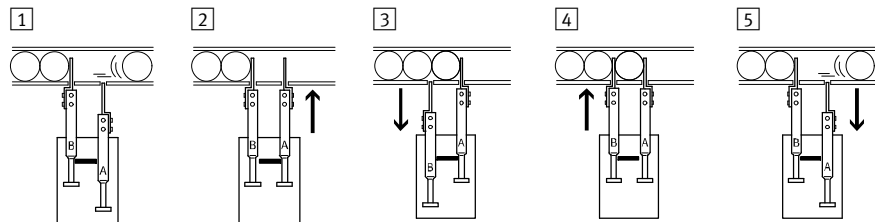

Size	10	14	22
Stroke	10	20	30
Half the cycle time	26.5	111.5	152.4
Cycle time	52.5	223	304.8

## Max. permissible weight [g] of add-on plunger separators for unrestricted operation

Size	10	14	22
Add-on plunger separators <sup>1)</sup>	56	150	395

1) If the max. permissible weights of the add-on plunger separators are exceeded, the retracting and advancing times must be adapted in accordance with the table below using one-way flow control valves. Failure to do so may result in components of the feed separator being damaged.

## Retracting and advancing times [s] with add-on plunger separators as a function of the load [g] of the fingers

Size	10	14	22	
Stroke	10	20	30	
Applied load	100 g	0.03	-	-
	200 g	0.04	0.03	0.05
	300 g	0.05	0.04	0.08
	400 g	0.06	0.05	0.11
	500 g	-	0.07	0.13
	600 g	-	-	0.3
	700 g	-	-	0.36
	800 g	-	-	0.42
				0.48
				0.6
				0.72
				0.84
				0.96

# Feed separators HPV

Technical data

FESTO

## Permissible characteristic static load values at the plungers

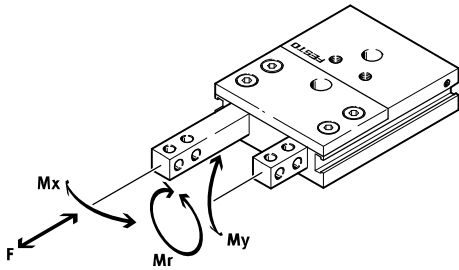

Size	10	14	22
Force F [N]	75	100	180
Torque $M_x$ [Nm]	3	5	9
Torque $M_y$ [Nm]	3	5	9
Torque $M_r$ [Nm]	3	5	9

## Plunger backlash

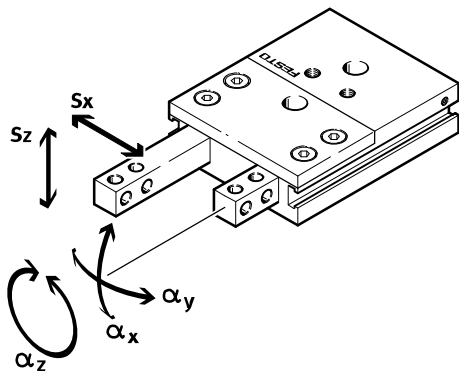

Size	10	14	Size	22	
Stroke	10	20	40	30	60
$S_x$ [mm]	0.05	0.05	0.05	0.05	0.05
$S_z$ [mm]	0.03	0.03	0.03	0.03	0.03
$\alpha_x$ [°]	0.12	0.12	0.07	0.06	0.04
$\alpha_y$ [°]	0.2	0.2	0.12	0.11	0.07
$\alpha_z$ [°]	0.262	0.175	0.175	0.12	0.12

## Minimum clearances

To prevent malfunctioning of the proximity sensors, the feed separators must comply with the minimum clearances specified in the table.

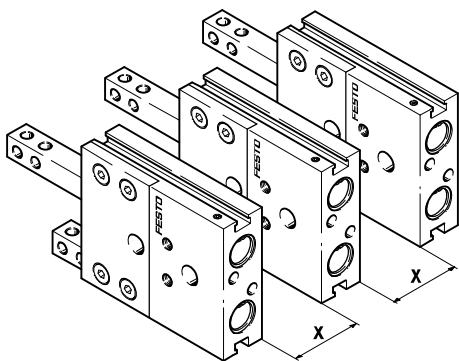

Size	10	14	22
For SME-8-... [mm]	60	59	73
For SMT-8-...-B [mm]	60	54	69

# Feed separators HPV

Technical data

## Projection of proximity sensors

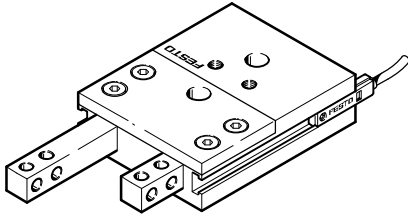

Size		10	14	22
For SME-8-...	[mm]	14		
For SMT-8-...	[mm]	22		

## Mounting options

Only the mounting surface on the underside (opposite the supply ports) may be used.

### From above via through-holes

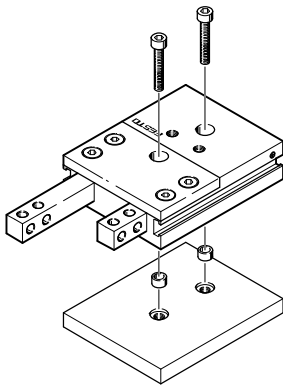

Size	10	14	22
Screw	M3	M4	M6
Permitted tightening torque [Nm]	1.2	2.9	9.9

### From below via female threads

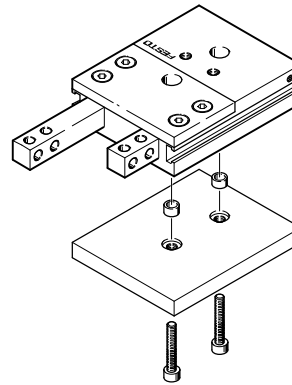

Size	10	14	22
Screw	M4	M5	M8
Permitted tightening torque [Nm]	2.9	5.9	24

## Surface finish and positional accuracy of bearing surface

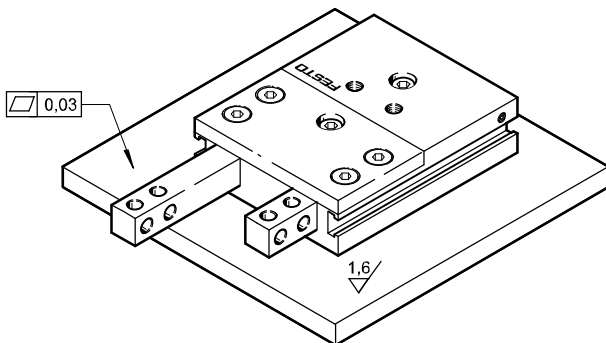

# Feed separators HPV

Technical data

FESTO

Dimensions Download CAD data → [www.festo.com](http://www.festo.com)

1 Slot for proximity sensor  
 2 Compressed air connection (optional)  
 3 Centring sleeves (2 pieces included in scope of delivery)  
 4 Stroke

Type	B1	B2	B3 ±0.02	B4 ±0.05	B5	D1 ∅	D2	D3 H8/h7 ∅	D4 H13 ∅	D5 H13 ∅	D6 H13 ∅	EE	EE1	H1
HPV-10-10-A	47	6	7	20	7	5.3	M4	7	6	–	3.2	M5	M3	78
HPV-14-20-A	60	12	10	30	10	5.3	M5	7	7.4	–	4.2	M5	M5	119
HPV-14-40-A	60	12	10	30	10	5.3	M5	7	7.4	–	4.2	M5	M5	189
HPV-22-30-A	78	13	14	38	11	8.4	M8	12	10.4	6.2	6.2	M5	M5	175
HPV-22-60-A	78	13	14	38	11	8.4	M8	12	10.4	6.2	6.2	M5	M5	280

Type	H2	H3	H4 ±0.1	H5 <sup>1)</sup>	H6 ±0.2	H7 ±0.1	H8 ±0.5	H9	L1	L2	T1 +0.1	T2	T3 min.	T5 –0.3
HPV-10-10-A	53	24.5	16	30	7	4	10	7.5	18	9	1.6	3.1	4	1.4
HPV-14-20-A	79	36	20	30	10	5	20	36	19	7	1.6	4.6	5	1.4
HPV-14-40-A	129	56	20	60	10	5	40	56	19	7	1.6	4.6	5	1.4
HPV-22-30-A	115	48	40	60	14	8	30	48	32	16	2.6	6.1	5	2.4
HPV-22-60-A	190	78	40	120	14	8	60	78	32	16	2.6	6.1	5	2.4

1) Tolerance for centring hole ±0.02  
 Tolerance for threaded and through-hole ±0.1

Ordering data			
Size	Stroke [mm]	Part No.	Type
10	10	550908	HPV-10-10-A
14	20	529351	HPV-14-20-A
	40	529352	HPV-14-40-A
22	30	529353	HPV-22-30-A
	60	529354	HPV-22-60-A



# Feed separators HPV

Accessories



FESTO

Ordering data		Technical data → Internet: zbh		
	For size	Part No.	Type	PU <sup>1)</sup>
Centring sleeve ZBH				
	10, 14	186717	ZBH-7	10
	22	189653	ZBH-12	10

1) Packaging unit quantity

Ordering data – Proximity sensors for T-slot, magneto-resistive					Technical data → Internet: smt	
	Type of mounting	Switch output	Electrical connection	Cable length [m]	Part No.	Type
N/O contact						
	Insertable in the slot from above, flush with cylinder profile, short design	PNP	Cable, 3-wire	2.5	574335	SMT-8M-A-PS-24V-E-2,5-OE
			Plug M8x1, 3-pin	0.3	574334	SMT-8M-A-PS-24V-E-0,3-M8D

Ordering data – Proximity sensors for T-slot, magnetic reed					Technical data → Internet: sme	
	Type of mounting	Switch output	Electrical connection	Cable length [m]	Part No.	Type
N/O contact						
	Insertable in the slot lengthwise, flush with the cylinder profile	Via contact	Cable, 3-wire	2.5	150855	SME-8-K-LED-24
			Plug M8x1, 3-pin	0.3	150857	SME-8-S-LED-24

Ordering data – Connecting cables				Technical data → Internet: nebu	
	Electrical connection, left	Electrical connection, right	Cable length [m]	Part No.	Type
	Straight socket, M8x1, 3-pin	Cable, open end, 3-wire	2.5	541333	NEBU-M8G3-K-2.5-LE3
			5	541334	NEBU-M8G3-K-5-LE3
	Straight socket, M12x1, 5-pin	Cable, open end, 3-wire	2.5	541363	NEBU-M12G5-K-2.5-LE3
			5	541364	NEBU-M12G5-K-5-LE3
	Angled socket, M8x1, 3-pin	Cable, open end, 3-wire	2.5	541338	NEBU-M8W3-K-2.5-LE3
			5	541341	NEBU-M8W3-K-5-LE3
	Angled socket, M12x1, 5-pin	Cable, open end, 3-wire	2.5	541367	NEBU-M12W5-K-2.5-LE3
			5	541370	NEBU-M12W5-K-5-LE3

Ordering data – Slot covers			Part No.	Type
	Mounting	Length [m]		
	Inserted from above	2 x 0.5	151680	ABP-5-S

Ordering data – One-way flow control valves				Technical data → Internet: grla-m5-qs	
	Connection		Material	Part No.	Type
	Thread	For tubing outer Ø			
	M5	3	Metal design	193137	GRLA-M5-QS-3-D
		4		193138	GRLA-M5-QS-4-D
		6		193139	GRLA-M5-QS-6-D

# Festo North America

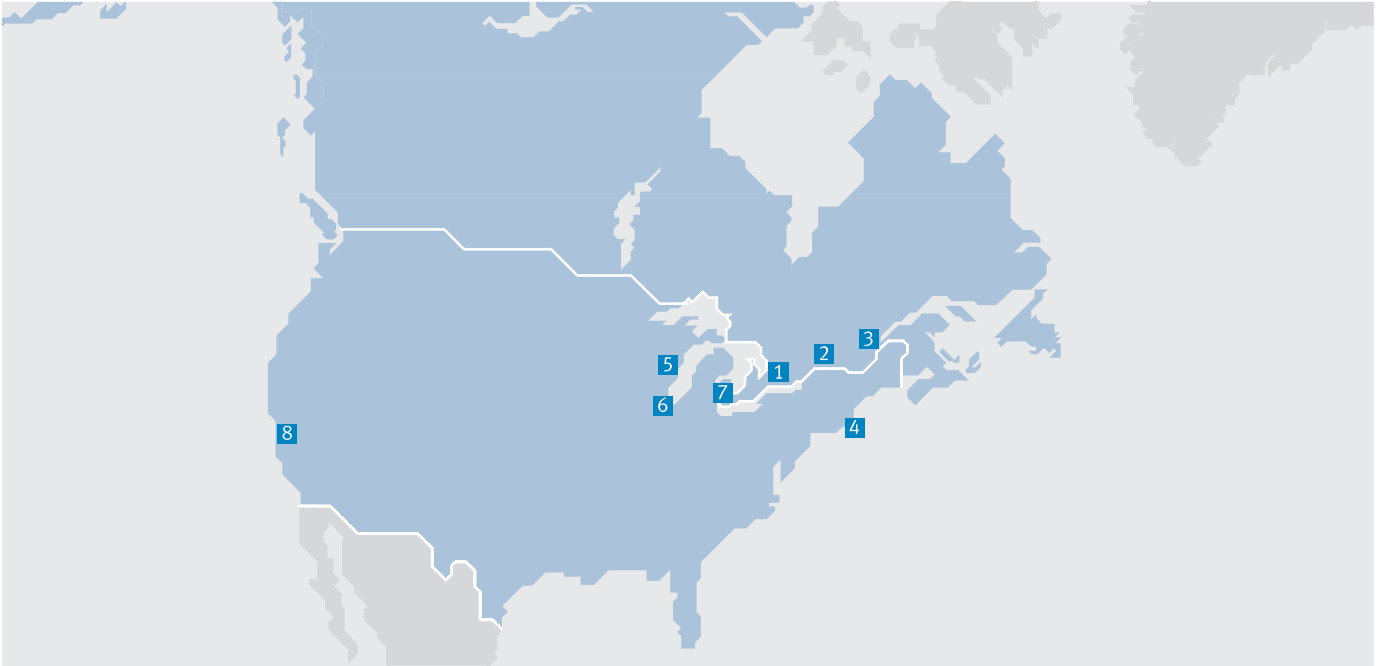

**1 Festo Canada  
Headquarters  
Festo Inc.**  
5300 Explorer Drive  
Mississauga, ON  
L4W 5G4

**2 Montréal**  
5600, Trans-Canada  
Pointe-Claire, QC  
H9R 1B6

**3 Québec City**  
2930, rue Watt#117  
Québec, QC  
G1X 4G3



**4 Festo United States  
Headquarters  
Festo Corporation**  
395 Moreland Road  
Hauppauge, NY  
11788

**5 Appleton**  
North 922 Tower View Drive, Suite N  
Greenville, WI  
54942

**7 Detroit**  
1441 West Long Lake Road  
Troy, MI  
48098

**6 Chicago**  
85 W Algonquin - Suite 340  
Arlington Heights, IL  
60005

**8 Silicon Valley**  
4935 Southfront Road, Suite F  
Livermore, CA  
94550

## Festo Regional Contact Center

### Canadian Customers

Commercial Support:  
Tel: 1 877 GO FESTO (1 877 463 3786)  
Fax: 1 877 FX FESTO (1 877 393 3786)  
Email: festo.canada@ca.festo.com

Technical Support:  
Tel: 1 866 GO FESTO (1 866 463 3786)  
Fax: 1 877 FX FESTO (1 877 393 3786)  
Email: technical.support@ca.festo.com

### USA Customers

Commercial Support:  
Tel: 1 800 99 FESTO (1 800 993 3786)  
Fax: 1 800 96 FESTO (1 800 963 3786)  
Email: customer.service@us.festo.com

Technical Support:  
Tel: 1 866 GO FESTO (1 866 463 3786)  
Fax: 1 800 96 FESTO (1 800 963 3786)  
Email: product.support@us.festo.com

Subject to change

Internet: [www.festo.com/us](http://www.festo.com/us)