

Toothed belt axes ELGC-TB-KF

FESTO

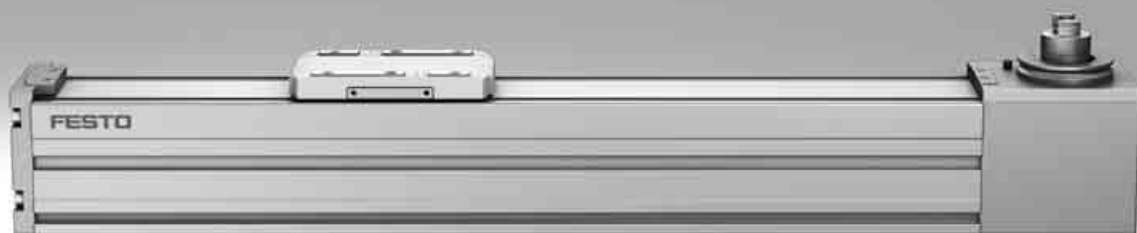

Electromechanical drives

Selection aid



Overview of toothed belt and spindle axes

Toothed belt axes

- Speeds of up to 10 m/s
- Acceleration of up to 50 m/s²
- Repetition accuracy of up to ±0.08 mm
- Strokes of up to 8500 mm (longer strokes on request)
- Flexible motor mounting

Spindle axes

- Speeds of up to 2 m/s
- Acceleration of up to 20 m/s²
- Repetition accuracy of up to ±0.003 mm
- Strokes of up to 3000 mm

Coordinate system

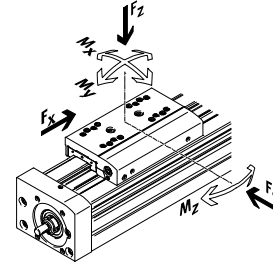

Toothed belt axes

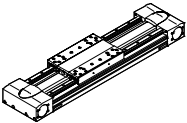
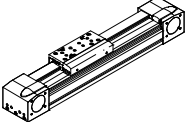
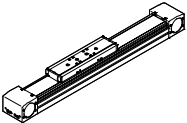
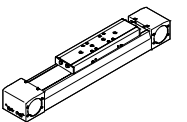
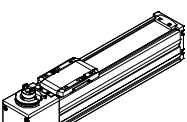
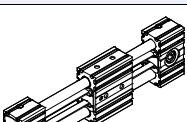
Type	F_x [N]	v [m/s]	M_x [Nm]	M_y [Nm]	M_z [Nm]	Features
Heavy-duty recirculating ball bearing guide						
EGC-HD-TB						
	450 1000 1800	3 5 5	140 300 900	275 500 1450	275 500 1450	<ul style="list-style-type: none"> • Flat drive unit with rigid, closed profile • Precision DUO guide rail with high load capacity • Ideal as a base axis for linear gantries and cantilever axes
Recirculating ball bearing guide						
EGC-TB-KF						
	50 100 350 800 2500	3 5 5 5 5	3.5 16 36 144 529	10 132 228 680 1820	10 132 228 680 1820	<ul style="list-style-type: none"> • Rigid, closed profile • Precision guide rail with high load capacity • Small drive pinions reduce required driving torque • Space-saving position sensing
ELGA-TB-KF						
	350 800 1300 2000	5 5 5 5	16 36 104 167	132 228 680 1150	132 228 680 1150	<ul style="list-style-type: none"> • Internal guide and toothed belt • Precision guide rail with high load capacity • Guide and toothed belt protected by cover band • High feed forces
ELGA-TB-KF-F1						
	260 600 1000	5 5 5	16 36 104	132 228 680	132 228 680	<ul style="list-style-type: none"> • Suitable for use in the food zone • "Clean Look": smooth, easy to clean surfaces • Internal guide and toothed belt • Precision guide rail with high load capacity • Guide and toothed belt protected by cover band
ELGC-TB-KF						
	75 120 250	1.2 1.5 1.5	5.5 29.1 59.8	4.7 31.8 56.2	4.7 31.8 56.2	<ul style="list-style-type: none"> • Internal guide and toothed belt • Precision guide rail with high load capacity • Guide and toothed belt protected by cover band
ELGR-TB						
	50 100 350	3 3 3	2.5 5 15	20 40 124	20 40 124	<ul style="list-style-type: none"> • Cost-optimised rod guide • Ready-to-install unit • Ball bearings with high load capacity for dynamic operation

Electromechanical drives

Selection aid

Overview of toothed belt and spindle axes

Toothed belt axes

- Speeds of up to 10 m/s
- Acceleration of up to 50 m/s²
- Repetition accuracy of up to ±0.08 mm
- Strokes of up to 8500 mm (longer strokes on request)
- Flexible motor mounting

Spindle axes

- Speeds of up to 2 m/s
- Acceleration of up to 20 m/s²
- Repetition accuracy of up to ±0.003 mm
- Strokes of up to 3000 mm

Coordinate system

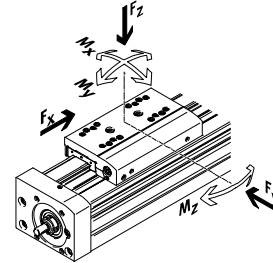

Toothed belt axes

Type	F_x [N]	v [m/s]	M_x [Nm]	M_y [Nm]	M_z [Nm]	Features
Roller bearing guide						
ELGA-TB-RF						
	350	10	11	40	40	<ul style="list-style-type: none"> • Heavy-duty roller bearing guide • Guide and toothed belt protected by cover band • Speeds of up to 10 m/s • Lower weight than axes with guide rails
	800	10	30	180	180	
	1300	10	100	640	640	
ELGA-TB-RF-F1						
	260	10	8.8	32	32	<ul style="list-style-type: none"> • Suitable for use in the food zone • "Clean Look": smooth, easy to clean surfaces • Heavy-duty roller bearing guide • Guide and toothed belt protected by cover band • Lower weight than axes with guide rails
	600	10	24	144	144	
	1000	10	80	512	512	
Plain-bearing guide						
ELGA-TB-G						
	350	5	5	30	10	<ul style="list-style-type: none"> • Guide and toothed belt protected by cover band • For simple handling tasks • As a drive component for external guides • Insensitive to harsh operating conditions
	800	5	10	60	20	
	1300	5	120	120	40	
ELGR-TB-GF						
	50	1	1	10	10	<ul style="list-style-type: none"> • Cost-optimised rod guide • Ready-to-install unit • Heavy-duty plain bearings for use in harsh operating conditions
	100	1	2.5	20	20	
	350	1	1	40	40	

Electromechanical drives

Selection aid



Overview of toothed belt and spindle axes

Toothed belt axes	Spindle axes	Coordinate system
<ul style="list-style-type: none"> • Speeds of up to 10 m/s • Acceleration of up to 50 m/s² • Repetition accuracy of up to ±0.08 mm • Strokes of up to 8500 mm (longer strokes on request) • Flexible motor mounting 	<ul style="list-style-type: none"> • Speeds of up to 2 m/s • Acceleration of up to 20 m/s² • Repetition accuracy of up to ±0.003 mm • Strokes of up to 3000 mm 	

Spindle axes						
Type	F_x [N]	v [m/s]	M_x [Nm]	M_y [Nm]	M_z [Nm]	Features
Heavy-duty recirculating ball bearing guide						
EGC-HD-BS						
	300 600 1300	0.5 1.0 1.5	140 300 900	275 500 1450	275 500 1450	<ul style="list-style-type: none"> • Flat drive unit with rigid, closed profile • Precision DUO guide rail with high load capacity • Ideal as a base axis for linear gantries and cantilever axes
Recirculating ball bearing guide						
EGC-BS-KF						
	300 600 1300 3000	0.5 1.0 1.5 2.0	16 36 144 529	132 228 680 1820	132 228 680 1820	<ul style="list-style-type: none"> • Rigid, closed profile • Precision guide rail with high load capacity • For the highest requirements in terms of feed force and accuracy • Space-saving position sensing
ELGA-BS-KF						
	300 600 1300 3000	0.5 1.0 1.5 2.0	16 36 104 167	132 228 680 1150	132 228 680 1150	<ul style="list-style-type: none"> • Internal guide and ball screw • Precision guide rail with high load capacity • For the highest requirements in terms of feed force and accuracy • Guide and ball screw protected by cover band • Space-saving position sensing
ELGC-BS-KF						
	110 240 480 780	0.6 0.6 0.8 1.0	1.3 5.5 29.1 59.8	1.1 4.7 31.8 56.2	1.1 4.7 31.8 56.2	<ul style="list-style-type: none"> • Internal guide and ball screw • Guide and ball screw protected by cover band • Space-saving position sensing
EGSK						
	57 133 184 239 392	0.33 1.10 0.83 1.10 1.48	13 28.7 60 79.5 231	3.7 9.2 20.4 26 77.3	3.7 9.2 20.4 26 77.3	<ul style="list-style-type: none"> • Spindle axes with maximum accuracy, compactness and rigidity • Recirculating ball bearing guide and ball screw without caged ball bearings • Standard designs in stock
EGSP						
	112 212 466 460	0.6 0.6 2.0 2.0	36.3 81.5 90.3 258	12.5 31.6 32.1 94	12.5 31.6 32.1 94	<ul style="list-style-type: none"> • Spindle axes with maximum accuracy, compactness and rigidity • Recirculating ball bearing guide with caged ball bearings • Ball screw sizes 33, 46 with caged ball bearings

Toothed belt axes ELGC-TB-KF, with recirculating ball bearing guide

Features

At a glance

- The toothed belt axes, spindle axes ELGC and mini slides EGSC form a scalable modular system for compact automation
- The common platform architecture provides an integrated range with matching interfaces. A wide variety of systems can be achieved without using any adapter plates
- High-performance drive and guide elements ensure long service life, load carrying ability and reliability
- The uniform, universal range of accessories reduces warehousing and design work

Cantilever system

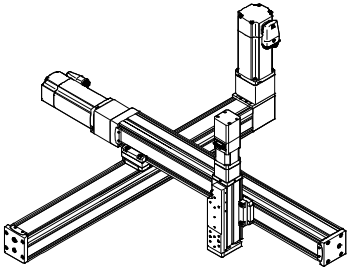

Planar surface gantry

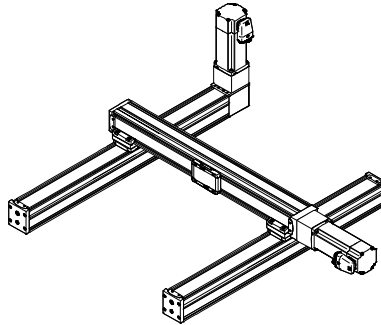

Three-dimensional gantry

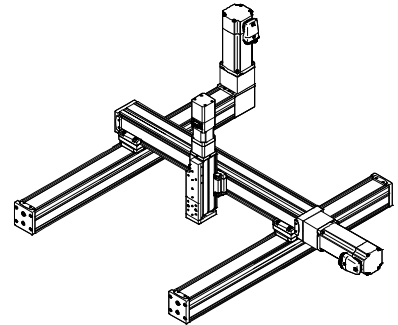

Complete system comprising motor, motor controller and motor mounting kit

Motor



- 1 Servo motor EMME-AS, EMMS-AS
- 2 Stepper motor EMMS-ST

Motor controller



- 1 Servo motor controller CMMP-AS
- 2 Stepper motor controller CMMO-ST

 **Note**
A range of specially adapted complete solutions is available for the toothed belt axis ELGC and the motors.

Motor mounting kit
Axial kit



- Kit comprising:
- Motor flange
 - Coupling housing
 - Coupling
 - Screws

Toothed belt axes ELGC-TB-KF, with recirculating ball bearing guide

Key features

Combination matrix between axis ELGC-TB, ELGC-BS, mini slide EGSC-BS and guide axis ELFC

With profile mounting EAHF-L2-...-P-D...

- For axis/axis mounting without adapter plate
- Mounting option: base axis with next smallest assembly axis

	Size	Assembly axis ELGC-BS/-TB; ELFC; EGSC-BS			
		25	32	45	60
Base axis	32	■	–	–	–
ELGC-BS/-TB; ELFC	45	–	■	–	–
	60	–	–	■	–
	80	–	–	–	■

Sample applications

Toothed belt axis ELGC-TB – Mini slide EGSC-BS

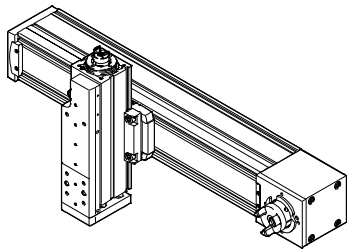

Spindle axis ELGC-BS – Mini slide EGSC-BS

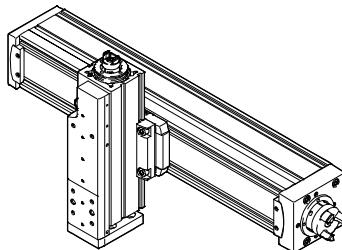

Toothed belt axis ELGC-TB – Spindle axis ELGC-BS

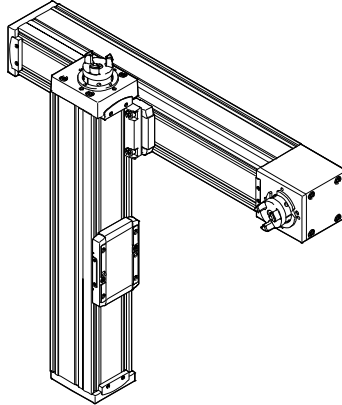
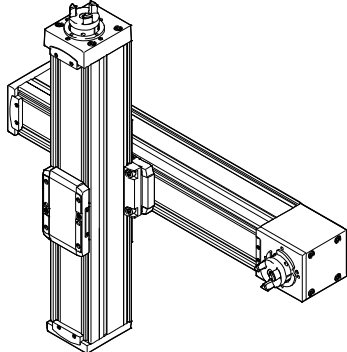

Toothed belt axes ELGC-TB-KF, with recirculating ball bearing guide

Key features

Combination matrix between axis ELGC-TB, ELGC-BS, mini slide EGSC-BS and guide axis ELFC

With adapter kit EHAA-D-L2

- For axis/axis mounting with adapter plate
- Mounting option: base axis with the same size or next smallest assembly axis
- When motors are assembled using parallel kits, interfering contours may occur. In this case, the adapter plate is required for height compensation (download CAD data → www.festo.com)

	Size	Assembly axis ELGC-BS/-TB; ELFC; EGSC-BS				
		25	32	45	60	80
Base axis	32		■	–	–	–
ELGC-BS/-TB; ELFC	45	–		■	–	–
	60	–	–		■	–
	80	–	–	–		■

Sample applications

Toothed belt axis ELGC-TB – Mini slide EGSC-BS

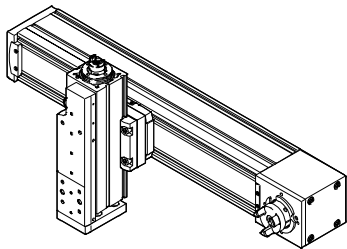

Spindle axis ELGC-BS – Mini slide EGSC-BS

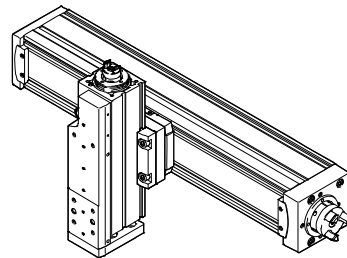

Toothed belt axis ELGC-TB – Spindle axis ELGC-BS

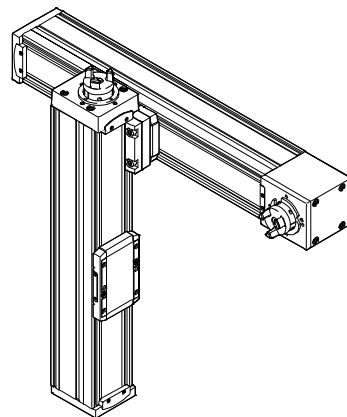
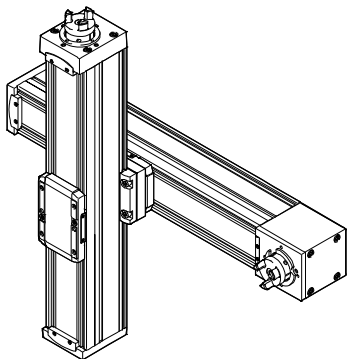

Toothed belt axes ELGC-TB-KF, with recirculating ball bearing guide

Key features

Combination matrix between axis ELGC-TB, ELGC-BS, mini slide EGSC-BS and guide axis ELFC

With angle kit EHAA-D-L2-...-AP

- For mounting the next smallest vertical axes (assembly axes) on base axes with mounting position “slide at top”

	Size	Assembly axis ELGC-BS/-TB; ELFC; EGSC-BS			
		25	32	45	60
Base axis	32	■	-	-	-
ELGC-BS/-TB; ELFC	45	-	■	-	-
	60	-	-	■	-
	80	-	-	-	■

Sample applications

Toothed belt axis ELGC-TB – Spindle axis ELGC-BS

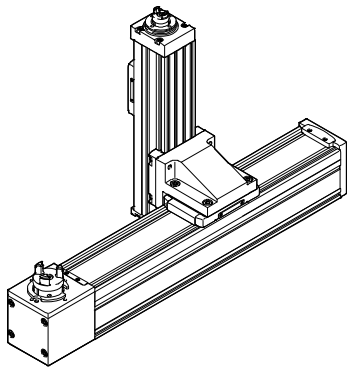

Toothed belt axis ELGC-TB – Mini slide EGSC-BS

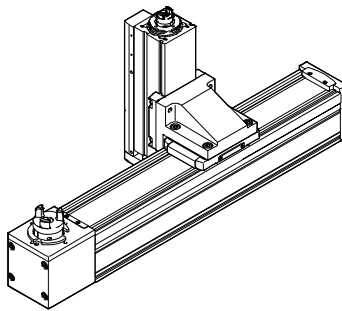

Spindle axis ELGC-BS – Mini slide EGSC-BS

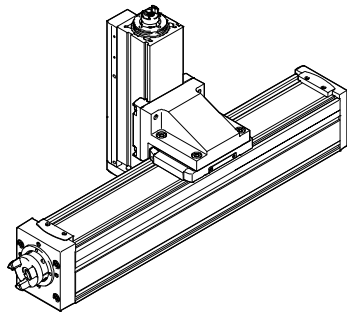

Toothed belt axes ELGC-TB-KF, with recirculating ball bearing guide

Type codes

		ELGC	-	TB	-	KF	-	60	-	800
Type										
ELGC	Toothed belt axis									
Drive system										
TB	Toothed belt									
Guide										
KF	Recirculating ball bearing guide									
Size										
Stroke [mm]										

Toothed belt axes ELGC-TB-KF, with recirculating ball bearing guide

Peripherals overview

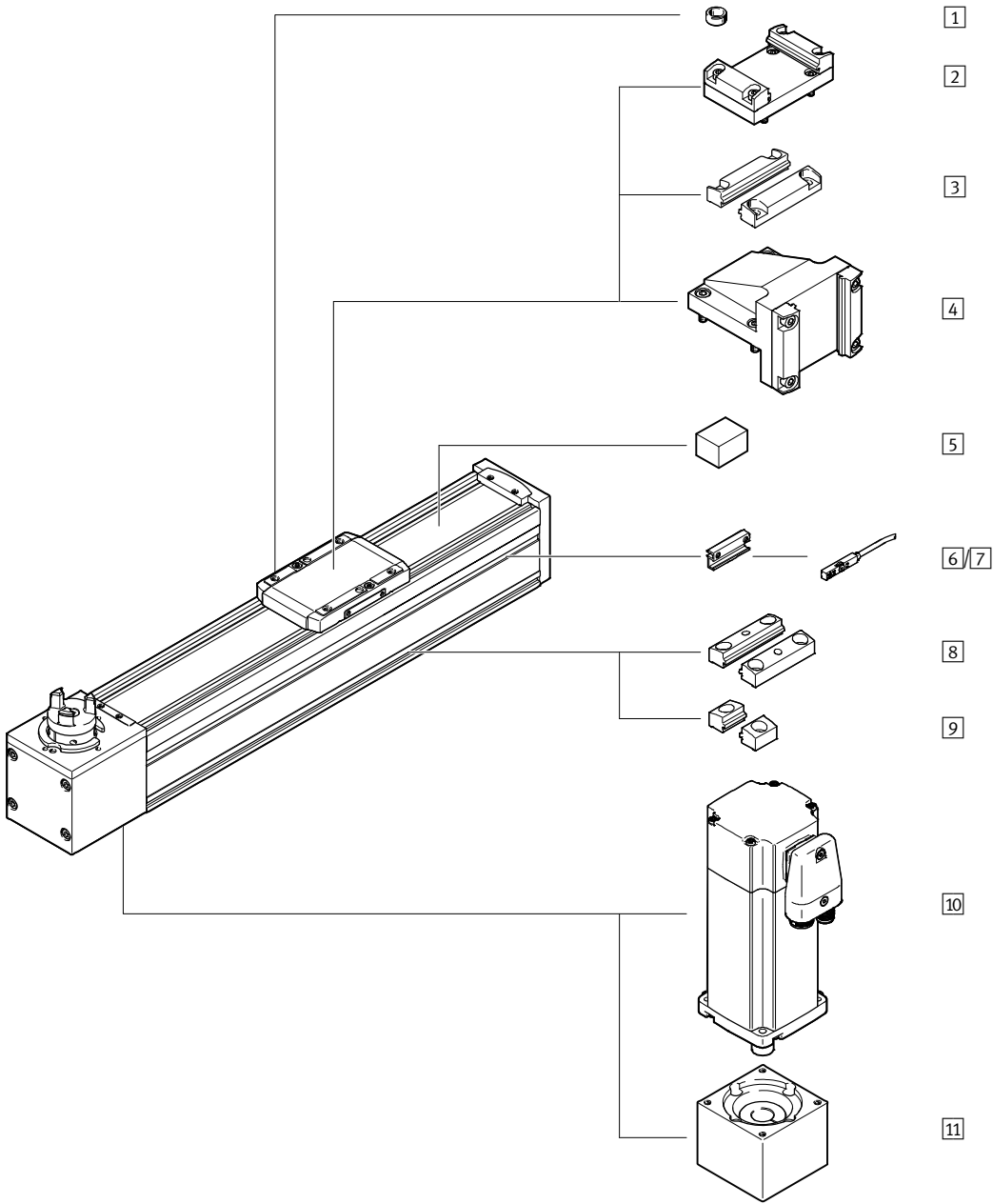

Toothed belt axes ELGC-TB-KF, with recirculating ball bearing guide

Peripherals overview



Accessories		
Type	Description	→ Page/Internet
1 Centring pin/sleeve ZBS/ZBH	For centring loads and attachments on the slide	29
2 Adapter kit EHAA-D-L2	<ul style="list-style-type: none"> For axis/axis mounting with adapter plate Mounting option: the same size or the next smallest assembly axis (→ page 7) When motors are assembled using parallel kits, interfering contours may occur. In this case, the adapter plate is required for height compensation (download CAD data → www.festo.com) 	27
3 Profile mounting EAHF-L2-...-P-D...	<ul style="list-style-type: none"> For axis/axis mounting without adapter plate Mounting option: base axis with the next smallest assembly axis (→ page 6) 	26
4 Angle kit EHAA-D-L2-...-AP	For mounting the next smallest vertical axes (assembly axes) on base axes with mounting position “slide at top” (→ page 8)	28
5 Clamping element EADT-S-L5-32	Tool for retensioning the cover band	29
6 Sensor bracket EAPM-L2-SH	For mounting the proximity sensors on the axis. The proximity sensors can only be mounted using the sensor bracket	29
7 Proximity sensor SMT-8M	Magnetic proximity sensor, for T-slot	30
8 Profile mounting EAHF-L2-...-P	For mounting the axis on the side of the profile. The profile mounting can be fixed in place on the mounting surface using the drill hole in the centre	25
9 Profile mounting EAHF-L2-...-P-S	For mounting the axis on the side of the profile	24
10 Motor EMME-AS, EMMS-ST	Motors specially matched to the axis	23
11 Axial kit EAMM-A	For axial motor mounting	23

Toothed belt axes ELGC-TB-KF, with recirculating ball bearing guide

Technical data

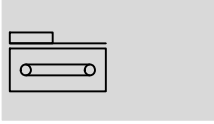
Function



-  - Size
45 ... 80
-  - Stroke length
200 ... 2000 mm
-  - www.festo.com



General technical data				
Size		45	60	80
Design		Electromechanical axis with toothed belt		
Guide		Recirculating ball bearing guide		
Mounting position		Any		
Working stroke	[mm]	200, 300, 500, 600, 800, 1000, 1200, 1500	200, 300, 500, 600, 800, 1000, 1200, 1500, 1800, 2000	200, 300, 500, 600, 800, 1000, 1200, 1500, 1800, 2000
Max. feed force F_x	[N]	75	120	250
Max. no-load torque ¹⁾	[Nm]	0.075	0.194	0.413
Max. no-load resistance to shifting ¹⁾	[N]	7.8	15.6	24.7
Max. driving torque	[Nm]	0.716	1.49	4.178
Max. speed	[m/s]	1.2	1.5	1.5
Max. acceleration	[m/s ²]	15		
Repetition accuracy	[mm]	±0.1		

1) At 0.2 m/s

Operating and environmental conditions		
Ambient temperature ¹⁾	[°C]	0 ... +50
Degree of protection		IP40
Duty cycle	[%]	100
Maintenance interval		Life-time lubrication

1) Note operating range of proximity sensors

Weight [g]				
Size		45	60	80
Basic weight with 0 mm stroke ¹⁾		760	1775	3500
Additional weight per 10 mm stroke		23	43	73
Moving load		169	482	901

1) Including slide

Toothed belt				
Size		45	60	80
Pitch	[mm]	2	3	3
Expansion ¹⁾	[%]	0.187	0.124	0.200
Effective diameter	[mm]	19.1	24.83	33.42
Feed constant	[mm/rev.]	60	78	105

1) At max. feed force

Toothed belt axes ELGC-TB-KF, with recirculating ball bearing guide

FESTO

Technical data

Mass moment of inertia				
Size		45	60	80
J_0	[kg mm ²]	18.62	88.04	291.2
J_H per metre stroke	[kg mm ² /m]	2.81	8.51	19.27
J_L per kg payload	[kg mm ² /kg]	91.19	154.11	279.3

The mass moment of inertia J_A of the entire axis is calculated as follows: $J_A = J_0 + J_H \times \text{working stroke [m]} + J_L \times m_{\text{payload [kg]}}$

Homing

Homing can be carried out in two ways:

- Against a fixed stop
- Using a reference switch

The following values must be observed:

Size		45	60	80
Max. impact energy	[J]	0.5×10^{-3}	1×10^{-3}	2×10^{-3}
At max. homing speed	[m/s]	0.01		

Materials

Sectional view

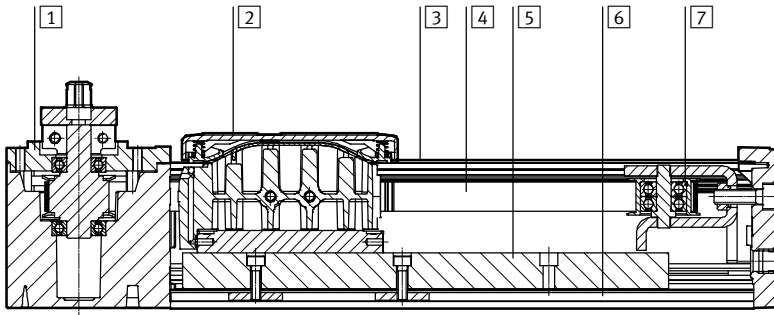

Axis		
1	Drive cover	Painted die-cast aluminium
2	Slide	Die cast aluminium
3	Cover strip	High-alloy stainless steel
4	Toothed belt	Polychloroprene with glass cord and nylon coating
5	Guide	Steel
6	Profile	Anodised wrought aluminium alloy
7	Guide pulley	Aluminium
	Note on materials	RoHS compliant
		Contains paint-wetting impairment substances

Toothed belt axes ELGC-TB-KF, with recirculating ball bearing guide

Technical data

Characteristic load values

The indicated forces and torques refer to the centre of the guide. The point of application of force is the point where the centre of the guide and the longitudinal centre of the slide intersect. These values must not be exceeded during dynamic operation. Special attention must be paid to the cushioning phase.

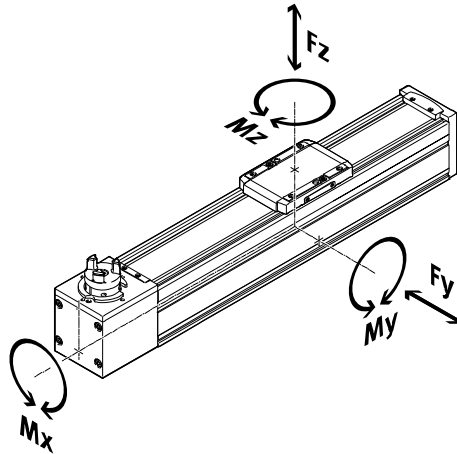

Distance from the slide surface to the centre of the guide

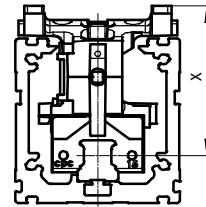

Max. permissible forces and torques on the slide (strength limits)				
Size		45	60	80
F _{y,max.}	[N]	300	600	900
F _{z,max.}	[N]	600	1800	2700
M _{x,max.}	[Nm]	5.5	29.1	59.8
M _{y,max.}	[Nm]	4.7	31.8	56.2
M _{z,max.}	[Nm]	4.7	31.8	56.2

Distance from the slide surface to the centre of the guide				
Size		45	60	80
Dimension x	[mm]	42.8	54.6	72.5

Max. permissible forces and torques for the bearing calculation, for a service life of 5000 km or 5 x 10 ⁶ cycles				
Size		45	60	80
F _{y,max.}	[N]	880	3641	5543
F _{z,max.}	[N]	880	3641	5543
M _{x,max.}	[Nm]	5.5	29.1	59.8
M _{y,max.}	[Nm]	4.7	31.8	56.2
M _{z,max.}	[Nm]	4.7	31.8	56.2

 **Note**

For a guide system to have a service life of 5000 km, the load comparison factor must have a value of $f_v < 1$, based on the maximum permissible forces and torques for a service life of 5000 km.

This formula can be used to calculate a guide value.

The engineering software "PositioningDrives" is available for more precise calculations → www.festo.com

If the axis is subjected to two or more of the indicated forces and torques simultaneously, the following equation must be satisfied in addition to the indicated maximum loads:

Calculating the load comparison factor:

$$f_v = \frac{|F_{y,dyn}|}{F_{y,max}} + \frac{|F_{z,dyn}|}{F_{z,max}} + \frac{|M_{x,dyn}|}{M_{x,max}} + \frac{|M_{y,dyn}|}{M_{y,max}} + \frac{|M_{z,dyn}|}{M_{z,max}}$$

Toothed belt axes ELGC-TB-KF, with recirculating ball bearing guide

Technical data

Calculating the service life

The service life of the guide depends on the load. To be able to make a statement as to the service life of the guide, the graph below plots the load comparison factor f_v against the service life.

These values are only theoretical. You must consult your local Festo contact for a load comparison factor f_v greater than 1.

Load comparison factor f_v as a function of service life l

Example:

A user wants to move an x kg load. Using the formula (→ page 14) gives a value of 1.5 for the load comparison factor f_v . According to the graph, the guide would have a service life of approx. 1500 km. Reducing the acceleration reduces the M_z and M_y values. A load comparison factor f_v of 1 now gives a service life of 5000 km.

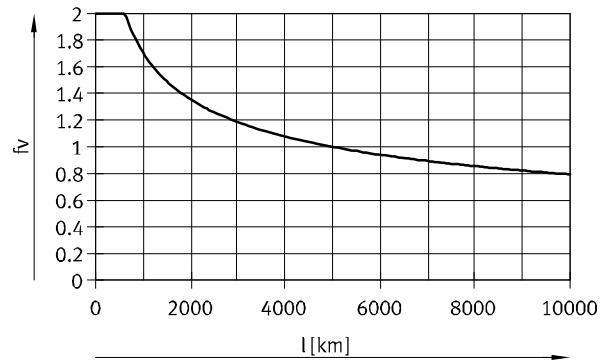

Comparison of the characteristic load values for 5000 km with dynamic forces and torques of recirculating ball bearing guides

The characteristic load values of roller guides are standardised to ISO and JIS using dynamic and static forces and torques. These forces and torques are based on an expected service life of the guide system of 100 km to ISO or 50 km to JIS. As the characteristic load values are dependent on the service life, the maximum permissible forces and torques for a 5000 km service life cannot be compared with the dynamic forces and torques of roller guides to ISO/JIS.

To make it easier to compare the guide capacity of linear axes ELGC with roller guides, the table below lists the theoretically permissible forces and torques for a calculated service life of 100 km. This corresponds to the dynamic forces and torques to ISO.

These 100 km values have been calculated mathematically and are only to be used for comparing with dynamic forces and torques to ISO. The drives must not be loaded with these characteristic values as this could damage the axes.

Max. permissible forces and torques for a theoretical service life of 100 km (from a guide perspective only)				
Size		45	60	80
$F_{y_{max}}$	[N]	3240	13400	20400
$F_{z_{max}}$	[N]	3240	13400	20400
$M_{x_{max}}$	[Nm]	20	107	220
$M_{y_{max}}$	[Nm]	17	117	207
$M_{z_{max}}$	[Nm]	17	117	207

Toothed belt axes ELGC-TB-KF, with recirculating ball bearing guide

Technical data

Feed force F as a function of input torque M

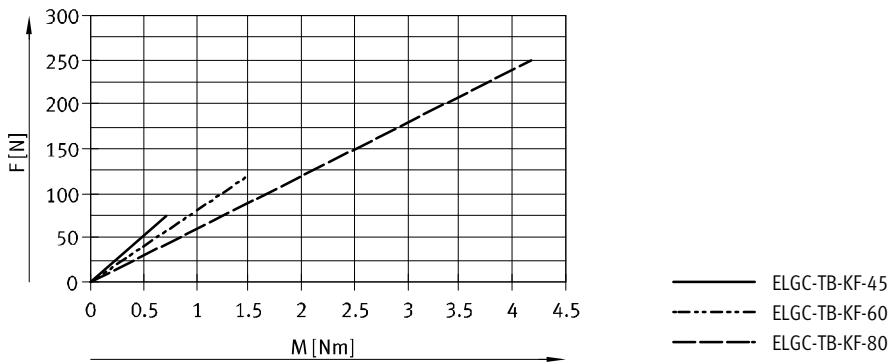

2nd moment of area

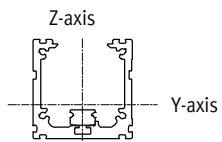

Size		45	60	80
ly	[mm ⁴]	140x10 ³	441x10 ³	1.37x10 ⁶
lz	[mm ⁴]	170x10 ³	542x10 ³	1.66x10 ⁶

Toothed belt axes ELGC-TB-KF, with recirculating ball bearing guide

Technical data

Maximum permissible support spacing L (without profile mounting) as a function of force F

In order to limit deflection in the case of large strokes, the axis may need to be supported.

The following graphs can be used to determine the maximum permissible support spacing L as a function of force F acting on the axis.

The deflection is $f = 0.5$ mm.

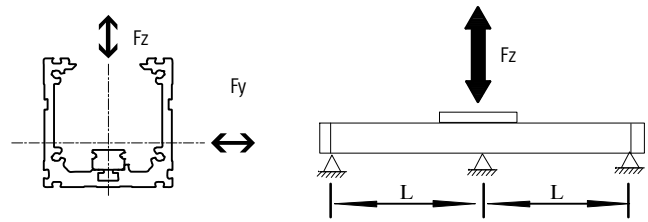

Force F_y
Size 45

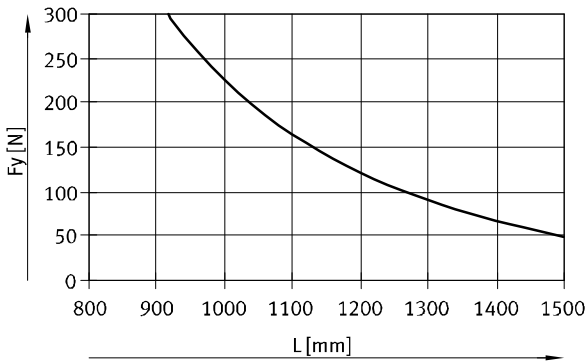

Size 60/80

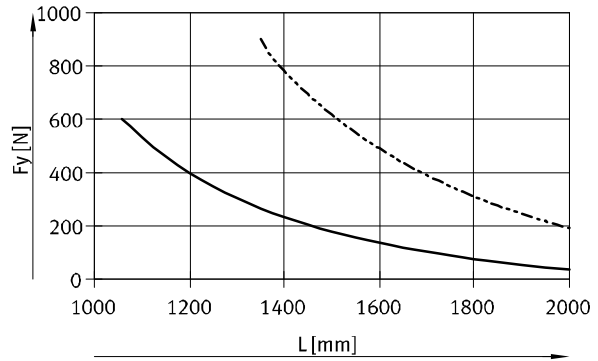

Force F_z
Size 45

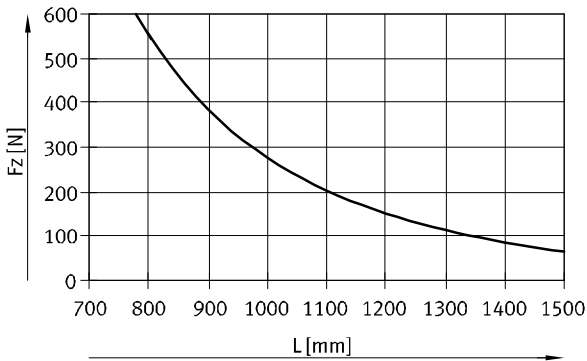

Size 60/80

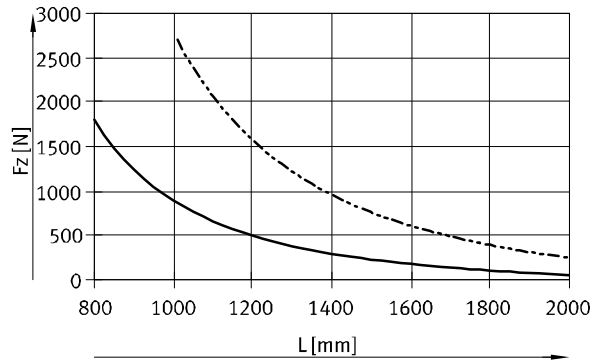

ELGC-TB-KF-45

ELGC-TB-KF-60

ELGC-TB-KF-80

Recommended deflection limits

Adherence to the following deflection limits is recommended so as not to impair the functional performance of the axes. Greater deformation can result in increased friction, greater wear and reduced service life.

Size	Dynamic deflection (moving load)	Static deflection (stationary load)
45 ... 80	0.05% of the axis length, max. 0.5 mm	0.1% of the axis length

Toothed belt axes ELGC-TB-KF, with recirculating ball bearing guide

Technical data

Dimensions

Download CAD data → www.festo.com

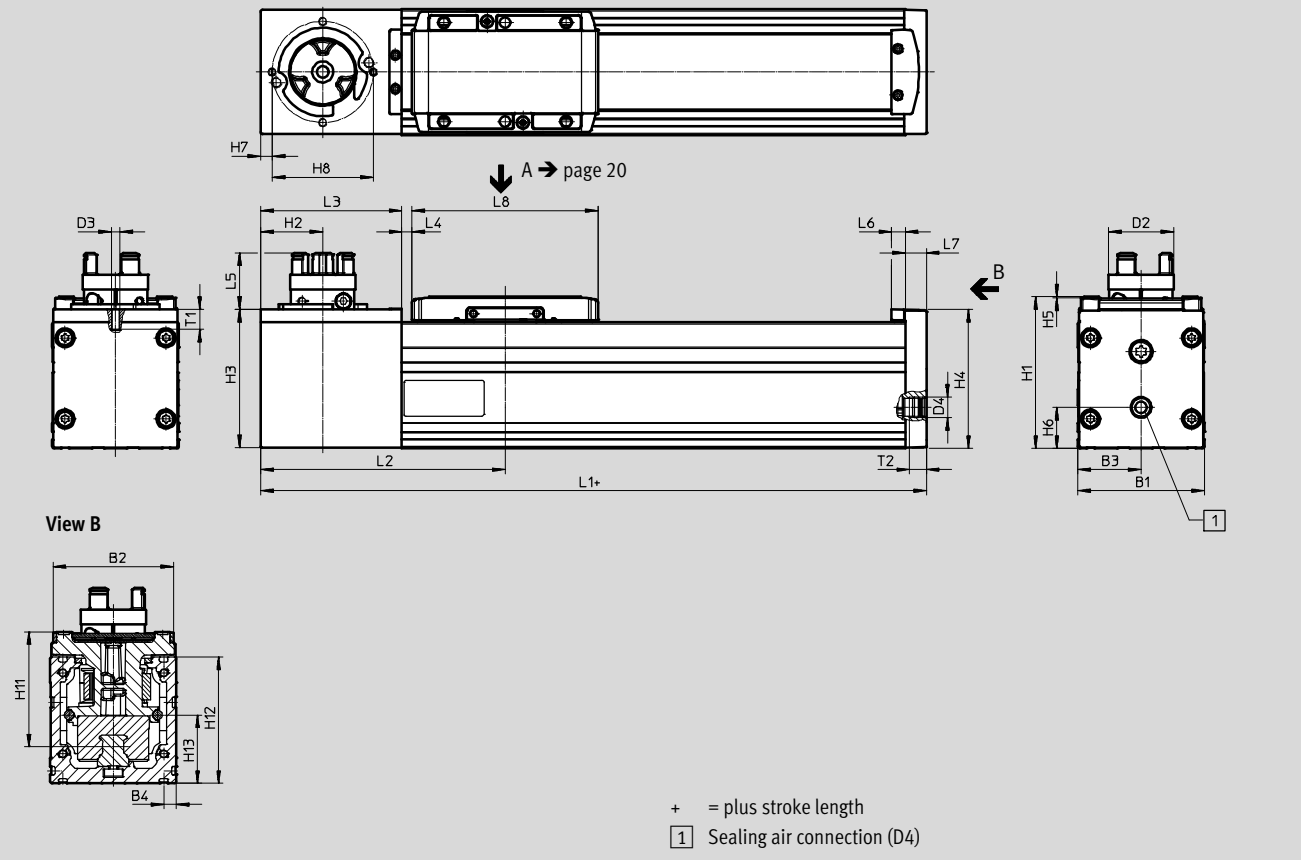

Size	B1	B2	B3	B4	D2 ∅	D3	D4	H1	H2
45	45	42.6	22.5	6.1	16.5	–	G1/8	54	22
60	60	57.1	30	6.1	31	M4	G1/8	72	29.5
80	80	77.1	40	6.1	31	M6	G1/8	96	39.5

Size	H3	H4	H5	H6	H7	H8	H11	H12	H13
45	49	49.6	0.5	12.5	–	–	42.8	45	18.5
60	65.5	66.1	0.5	19.5	5.5	48	54.6	60	32.5
80	85.5	88.1	0.5	20	7	65	72.5	80	41.5

Size	L1	L2	L3	L4 ¹⁾	L5	L6	L7	L8	T1	T2
		Min.		Min.						
45	165	90	52	4.25	19.9	6.5	7	67.5	–	8
60	216	116	67	4.75	26.9	6.5	10	88.5	9.5	8
80	260	145	87	5	25.9	6.5	12	106	12.5	8

1) Includes a stroke reserve of approx. 3 mm

Toothed belt axes ELGC-TB-KF, with recirculating ball bearing guide

Technical data

Dimensions

Download CAD data → www.festo.com

Profile

Size 45

Size 60

Size 80

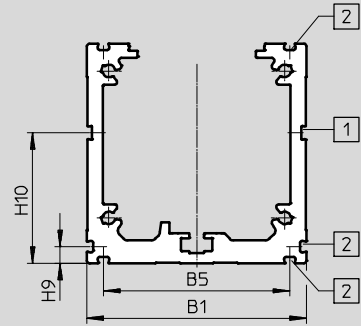
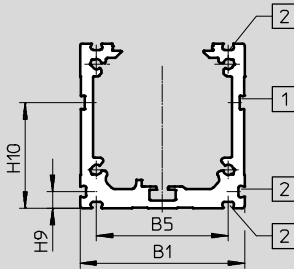
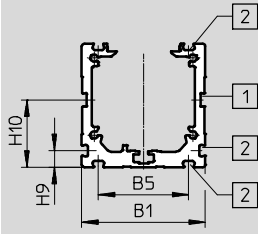

- 1 Slot for sensor bracket
- 2 Mounting slot

Size	B1	B5	H9	H10
45	45	32.9	6.1	24.5
60	60	47.9	6.1	38.5
80	80	67.9	6.1	47.5

Toothed belt axes ELGC-TB-KF, with recirculating ball bearing guide

Technical data

Dimensions Download CAD data → www.festo.com

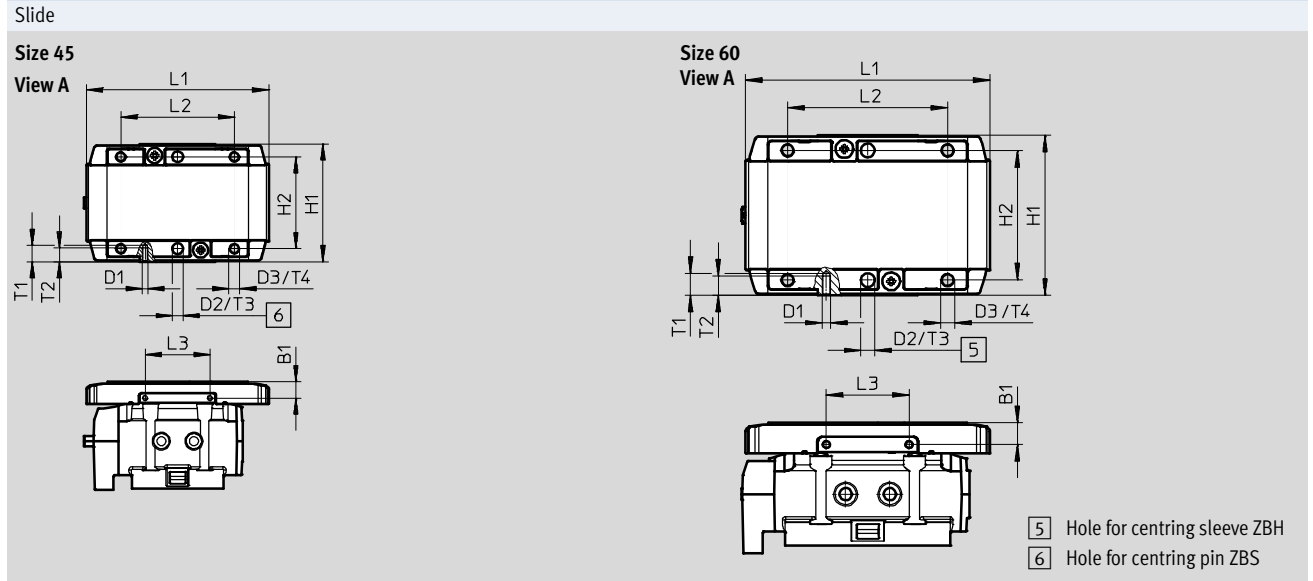

Size	B1 ±0.1	D1	D2 ∅ H8	D3	H1 ±0.1	H2 ±0.1 for D2 ±0.03
45	6	M2	4	M4	43.5	34
60	8	M3	5	M5	58	47

Size	L1	L2 ±0.1	L3 ±0.1	T1	T2	T3 +0.1	T4 ¹⁾
45	67.5	42	24	6	5	3.1	6 ... 7.5
60	88.5	58	30	9	7	1.3	8.5 ... 10

1) Recommended screw-in depth

Toothed belt axes ELGC-TB-KF, with recirculating ball bearing guide

Technical data

Dimensions

Download CAD data → www.festo.com

Slide

Size 80
View A

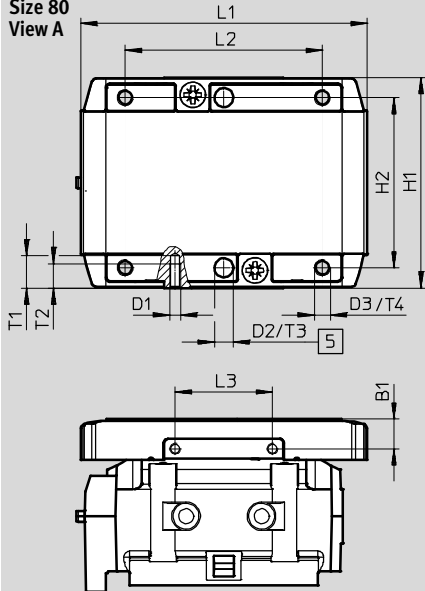

5 Hole for centring sleeve ZBH

Size	B1	D1	D2 ∅ H8	D3	H1	H2 ±0.1 for D2 ±0.03
80	±0.1 11	M4	7	M6	±0.1 78	63

Size	L1	L2 ±0.1	L3 ±0.1	T1	T2	T3 +0.1	T4 ¹⁾
80	106	73	36	12	9	1.6	11 ... 14

1) Recommended screw-in depth

Toothed belt axes ELGC-TB-KF, with recirculating ball bearing guide

Technical data

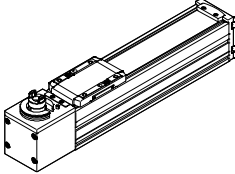
Ordering data				
	Size	Stroke [mm]	Part No.	Type
	45	200	8062768	ELGC-TB-KF-45-200
		300	8062769	ELGC-TB-KF-45-300
		500	8062770	ELGC-TB-KF-45-500
		600	8062771	ELGC-TB-KF-45-600
		800	8062772	ELGC-TB-KF-45-800
		1000	8062773	ELGC-TB-KF-45-1000
		1200	8062774	ELGC-TB-KF-45-1200
		1500	8062775	ELGC-TB-KF-45-1500
	60	200	8062776	ELGC-TB-KF-60-200
		300	8062777	ELGC-TB-KF-60-300
		500	8062778	ELGC-TB-KF-60-500
		600	8062779	ELGC-TB-KF-60-600
		800	8062780	ELGC-TB-KF-60-800
		1000	8062781	ELGC-TB-KF-60-1000
		1200	8062782	ELGC-TB-KF-60-1200
		1500	8062783	ELGC-TB-KF-60-1500
		1800	8062784	ELGC-TB-KF-60-1800
		2000	8062785	ELGC-TB-KF-60-2000
	80	200	8062786	ELGC-TB-KF-80-200
		300	8062787	ELGC-TB-KF-80-300
		500	8062788	ELGC-TB-KF-80-500
		600	8062789	ELGC-TB-KF-80-600
		800	8062790	ELGC-TB-KF-80-800
		1000	8062791	ELGC-TB-KF-80-1000
		1200	8062792	ELGC-TB-KF-80-1200
		1500	8062793	ELGC-TB-KF-80-1500
		1800	8062794	ELGC-TB-KF-80-1800
		2000	8062795	ELGC-TB-KF-80-2000

Toothed belt axes ELGC-TB-KF, with recirculating ball bearing guide

Accessories

 Note

Depending on the combination of motor and drive, it may not be possible to reach the maximum feed force of the drive.

Permissible axis/motor combinations with axial kit		Technical data → Internet: eamm-a
Motor ¹⁾	Axial kit	
Type	Part No.	Type
ELGC-TB-KF-45		
With servo motor		
EMME-AS-40-...	4595742	EAMM-A-V32-40P
EMME-AS-60-...	4608750	EAMM-A-V32-60P
With stepper motor		
EMMS-ST-42-...	4281142	EAMM-A-V32-42A
EMMS-ST-57-...	4597016	EAMM-A-V32-57A
ELGC-TB-KF-60		
With servo motor		
EMME-AS-60-...	4133487	EAMM-A-T42-60P
EMME-AS-80-...	4623788	EAMM-A-T42-80P
With stepper motor		
EMMS-ST-57-...	4327034	EAMM-A-T42-57A
EMMS-ST-87-...	4610008	EAMM-A-T42-87A
ELGC-TB-KF-80		
With servo motor		
EMME-AS-60-...	4824833	EAMM-A-T46-60P
EMME-AS-80-...	4624170	EAMM-A-T46-80P
EMME-AS-100-...	4624227	EAMM-A-T46-100A
EMMS-AS-100-...	4624227	EAMM-A-T46-100A
With stepper motor		
EMMS-ST-87-...	4048771	EAMM-A-T46-87A

1) The input torque must not exceed the maximum permissible transferable torque of the axial kit.

Toothed belt axes ELGC-TB-KF, with recirculating ball bearing guide

Accessories

Profile mounting EAHF-L2-...-P-S

Material:

Anodised wrought aluminium alloy

RoHS compliant

- For mounting the axis on the side of the profile

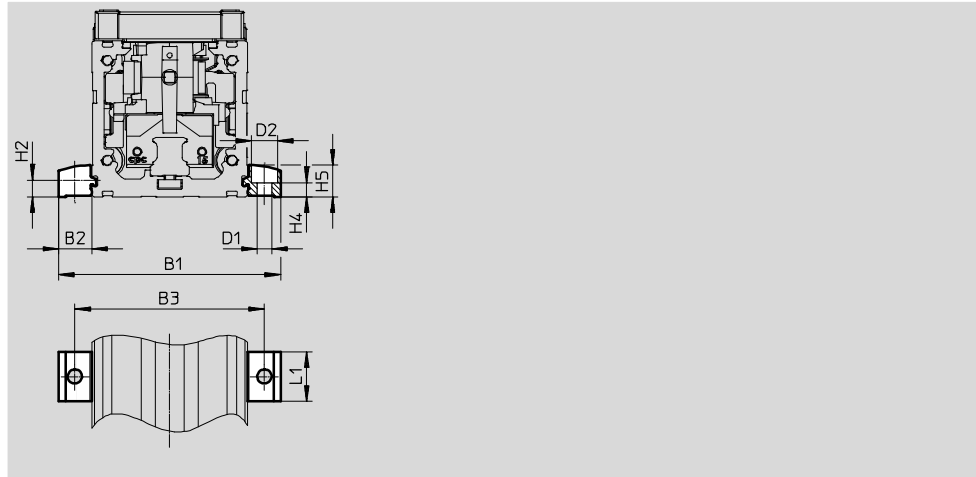

Dimensions and ordering data						
For size	B1	B2	B3	D1 ∅ H13	D2 ∅ H13	H2
45	70.6	12.8	58	5.5	10	6.1
60	85.6	12.8	73	5.5	10	6.1
80	105.6	12.8	93	5.5	10	6.1

For size	H4	H5	L1	Weight [g]	Part No.	Type
	±0.1					
45	5.5	12.2	19	6	5184133	EAHF-L2-45-P-S
60	5.5	12.2	19	6	5184133	EAHF-L2-45-P-S
80	5.5	12.2	19	6	5184133	EAHF-L2-45-P-S

Toothed belt axes ELGC-TB-KF, with recirculating ball bearing guide

Accessories

Profile mounting EAHF-L2-...-P

Material:

Anodised wrought aluminium alloy

RoHS compliant

- For mounting the axis on the side of the profile.
The profile mounting can be fixed in place on the mounting surface using the drill hole in the centre.

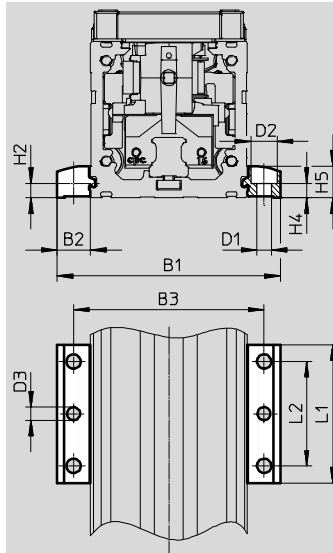

Dimensions and ordering data							
For size	B1	B2	B3	D1 Ø H13	D2 Ø H13	D3 Ø	H2
45	70.6	12.8	58	5.5	10	5	6.1
60	85.6	12.8	73	5.5	10	5	6.1
80	105.6	12.8	93	5.5	10	5	6.1

For size	H4	H5	L1	L2	Weight [g]	Part No.	Type
	±0.1						
45	5.5	12.2	53	40	35	4835728	EAHF-L2-45-P
60	5.5	12.2	53	40	35	4835728	EAHF-L2-45-P
80	5.5	12.2	53	40	35	4835728	EAHF-L2-45-P

Toothed belt axes ELGC-TB-KF, with recirculating ball bearing guide

Accessories

Profile mounting EAHF-L2-...-P-D...

Material:

Anodised wrought aluminium alloy

RoHS compliant

- For axis/axis mounting without adapter plate
- Mounting option: base axis with the next smallest assembly axis (→ page 6)

Combination matrix				
Size	2 Assembly axis ELGC-BS/-TB; ELFC; EGSC-BS			
	32	45	60	
1 Base axis	45	4759748	-	-
ELGC-BS/-TB, ELFC	60	-	4759739	-
	80	-	-	4759726

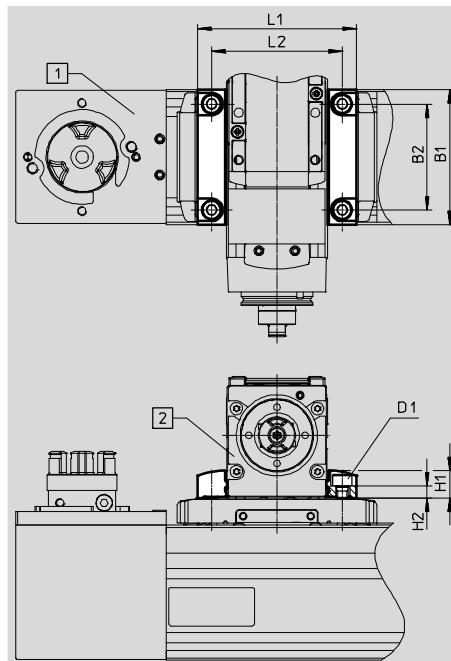

- 1 Base axis
- 2 Assembly axis

Dimensions and ordering data				
For combination (size)	B1	B2	D1	H1
45/32	45	34	M4	9
60/45	60	47	M5	12.2
80/60	78	63	M6	12.2

For combination (size)	H2 ±0.1	L1	L2	Weight [g]	Part No.	Type
45/32	3.7	51.4	42	24	4759748	EAHF-L2-25-P-D2
60/45	5.5	70.6	58	56	4759739	EAHF-L2-45-P-D3
80/60	4.5	85.6	73	77	4759726	EAHF-L2-45-P-D4

Toothed belt axes ELGC-TB-KF, with recirculating ball bearing guide

Accessories

Adapter kit EHAA-D-L2

Material:

Anodised wrought aluminium alloy

RoHS compliant

- For axis/axis mounting with adapter plate
- Mounting option: base axis with the same size or the next smallest assembly axis (→ page 7)
- When motors are assembled using parallel kits, interfering contours may occur. In this case, the adapter plate is required for height compensation (download CAD data → www.festo.com)

Combination matrix					
		[2] Assembly axis ELGC-BS/-TB; ELFC; EGSC-BS			
Size		32	45	60	80
[1] Base axis	45	8066714		-	-
ELGC-BS/-TB; ELFC	60	-	8066715		-
	80	-	-	8066716	

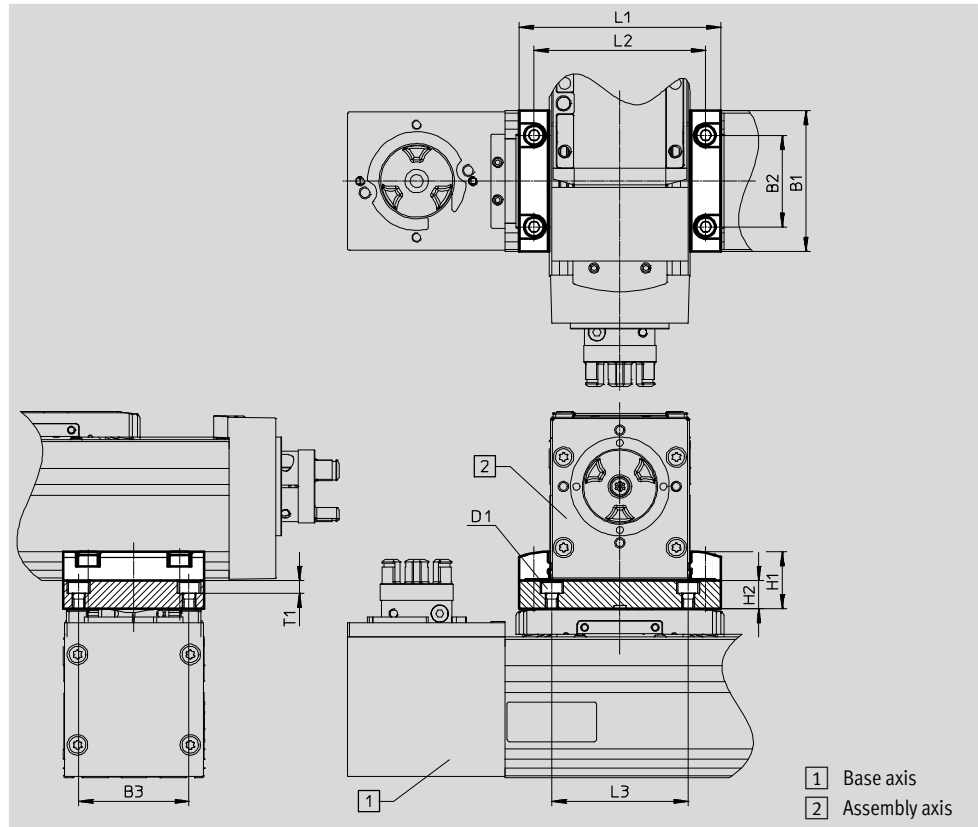

Dimensions and ordering data												
For combination (size)	B1	B3 ±0.05	D1	H1	H2	L1	L2	L3	T1	Weight [g]	Part No.	Type
45/32	45	34	M4	19	10	51.4	42	42	5.4	136	8066714	EHAA-D-L2-45-L2-45
60/45	60	47	M5	24.2	12	70.6	58	58	5.4	205	8066715	EHAA-D-L2-60-L2-60
80/60	78	63	M6	24.2	12	85.6	73	73	6.4	315	8066716	EHAA-D-L2-80-L2-80

For combination (size)	B1	B2	B3 ±0.05	D1	H1	H2	L1	L2	L3	T1	Weight [g]	Part No.	Type
45/45	45	32	34	M4	22.2	10	71	58	42	5.4	136	8066714	EHAA-D-L2-45-L2-45
60/60	60	39	47	M5	24.2	12	86	73	58	5.4	205	8066715	EHAA-D-L2-60-L2-60
80/80	78	63	63	M6	24.2	12	106	93	73	6.4	315	8066716	EHAA-D-L2-80-L2-80

Toothed belt axes ELGC-TB-KF, with recirculating ball bearing guide

Accessories

Angle kit EHAA-D-L2-...-AP

Materials:

Anodised wrought aluminium alloy

RoHS compliant

- For mounting the next smallest vertical axes (assembly axes) on base axes with mounting position “slide at top” (→ page 8)

Combination matrix				
Size	2 Assembly axis ELGC-BS/-TB; ELFC; EGSC-BS			
	32	45	60	
1 Base axis	45	8066718	-	-
ELGC-BS/-TB; ELFC	60	-	8066719	-
	80	-	-	8066720

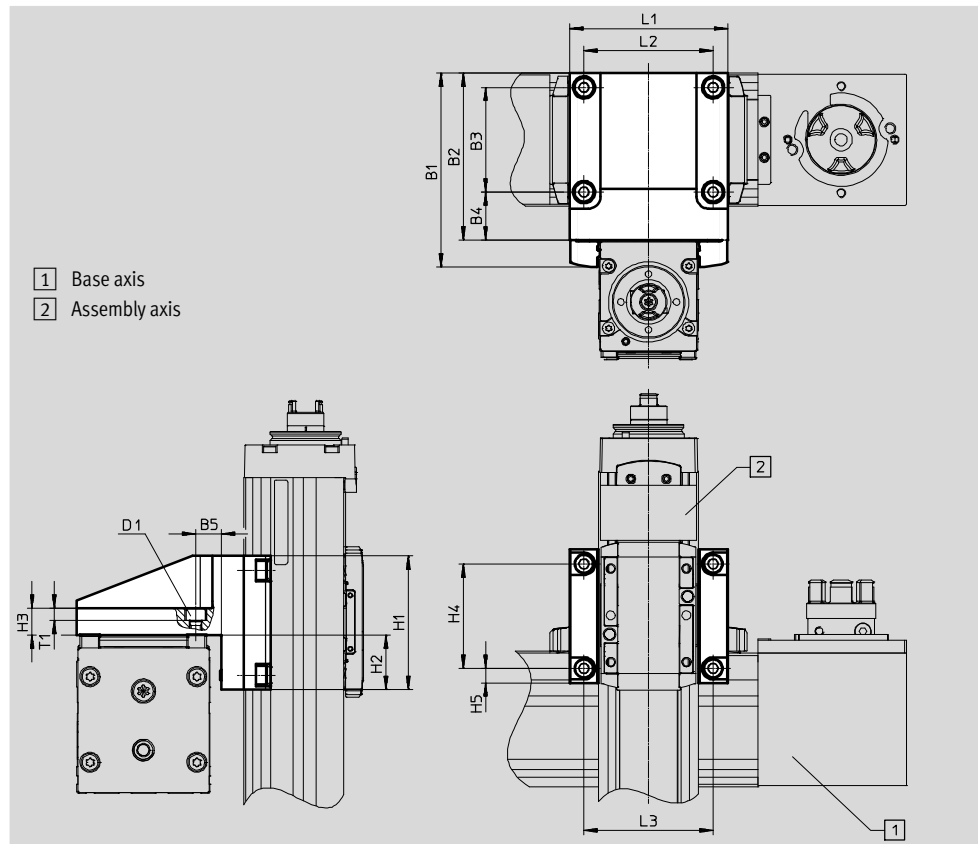

Dimensions and ordering data										
For combination (size)	B1	B2	B3	B4	B5	D1	H1	H2	H3	H4
45/32	69	60	34	20.5	11.5	M4	45	17.5	10	34
60/45	87.2	75	47	21.5	21.5	M5	60	24.5	12	47
80/60	107.2	95	63	23.5	23.5	M6	78	33.5	12	63

For combination (size)	H5	L1	L2	L3	T1	Weight [g]	Part No.	Type
45/32	5.5	52	42	42	5.4	222	8066718	EHAA-D-L2-45-L2-32-AP
60/45	6.5	71	58	58	5.4	433	8066719	EHAA-D-L2-60-L2-45-AP
80/60	7.5	86	73	73	6.4	768	8066720	EHAA-D-L2-80-L2-60-AP

Toothed belt axes ELGC-TB-KF, with recirculating ball bearing guide

Accessories

Sensor bracket EAPM-L2-SH

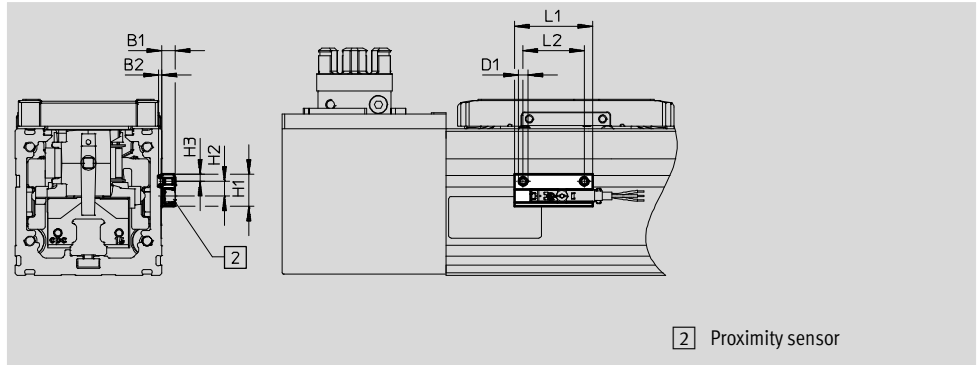

Materials:
Anodised wrought aluminium alloy
RoHS compliant



2 Proximity sensor

Dimensions and ordering data					
For size	B1	B2	D1	H1	H2
45, 60, 80	5.5	1.3	M4	13.4	6

For size	H3	L1	L2	Weight [g]	Part No.	Type
45, 60, 80	3	32	25	4	4759852	EAPM-L2-SH



Ordering data						
	For size	Description	Part No.	Type	PU ¹⁾	
Centring pin ZBS/centring sleeve ZBH						
	45	For slide	562959	ZBS-4	10	
	60		189652	ZBH-5		
	80		186717	ZBH-7		
Clamping element EADT						
	45	Tool for retensioning the cover band	8065818	EADT-S-L5-32	1	
	60, 80		8058451	EADT-S-L5-70		

1) Packaging unit quantity

Toothed belt axes ELGC-TB-KF, with recirculating ball bearing guide

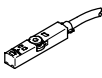
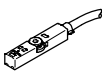
Accessories

Ordering data – Proximity sensor for T-slot, magneto-resistive					Technical data → Internet: smt	
	Type of mounting	Switching output	Electrical connection	Cable length [m]	Part No.	Type
N/O contact						
	Inserted in the slot from above, flush with the cylinder profile, short design	PNP	Cable, 3-wire	2.5	574335	SMT-8M-A-PS-24V-E-2,5-OE
			Plug connector M8x1, 3-pin	0.3	574334	SMT-8M-A-PS-24V-E-0,3-M8D
N/C						
	Inserted in the slot from above, flush with the cylinder profile, short design	PNP	Cable, 3-wire	7.5	574340	SMT-8M-A-PO-24V-E-7,5-OE

Ordering data – Connecting cables				Technical data → Internet: nebu	
	Electrical connection, left	Electrical connection, right	Cable length [m]	Part No.	Type
	Straight socket, M8x1, 3-pin	Cable, open end, 3-wire	2.5	541333	NEBU-M8G3-K-2.5-LE3
			5	541334	NEBU-M8G3-K-5-LE3
	Angled socket, M8x1, 3-pin	Cable, open end, 3-wire	2.5	541338	NEBU-M8W3-K-2.5-LE3
			5	541341	NEBU-M8W3-K-5-LE3

Festo North America

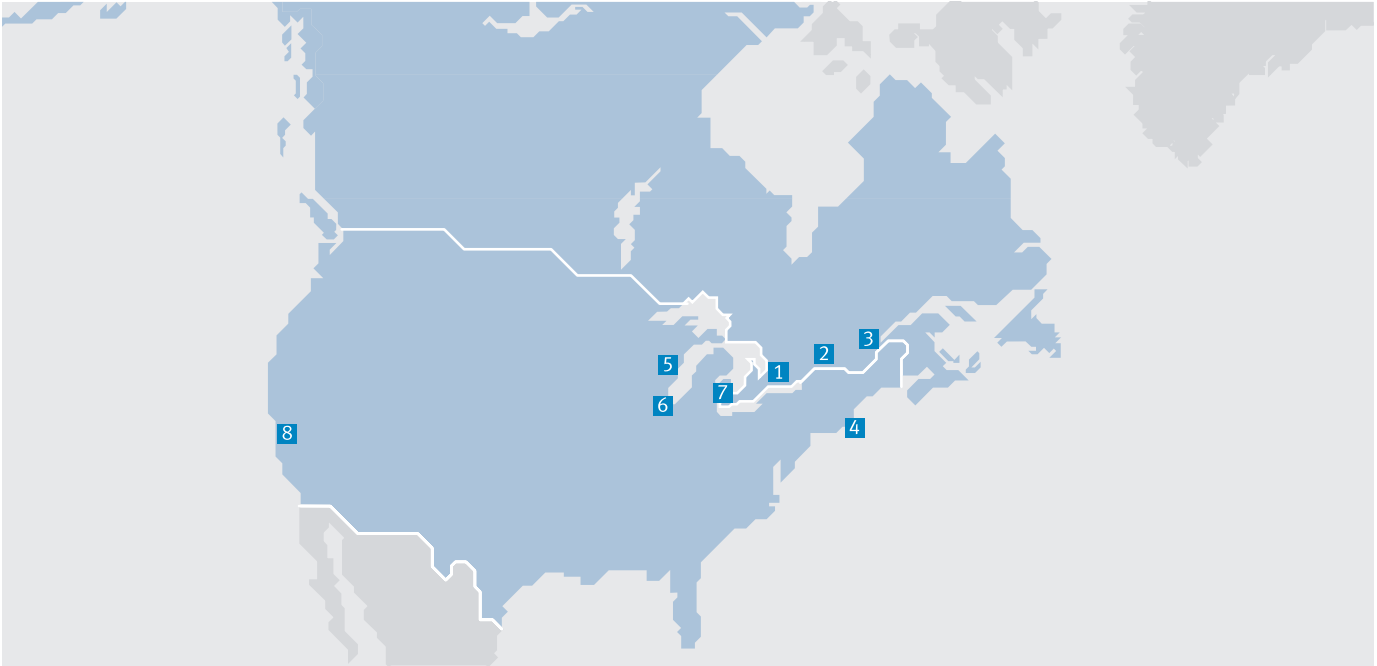

**1 Festo Canada
Headquarters
Festo Inc.**
5300 Explorer Drive
Mississauga, ON
L4W 5G4

2 Montréal
5600, Trans-Canada
Pointe-Claire, QC
H9R 1B6

3 Québec City
2930, rue Watt#117
Québec, QC
G1X 4G3



**4 Festo United States
Headquarters
Festo Corporation**
395 Moreland Road
Hauppauge, NY
11788

5 Appleton
North 922 Tower View Drive, Suite N
Greenville, WI
54942

7 Detroit
1441 West Long Lake Road
Troy, MI
48098

6 Chicago
85 W Algonquin - Suite 340
Arlington Heights, IL
60005

8 Silicon Valley
4935 Southfront Road, Suite F
Livermore, CA
94550

Festo Regional Contact Center

Canadian Customers

Commercial Support:
Tel: 1 877 GO FESTO (1 877 463 3786)
Fax: 1 877 FX FESTO (1 877 393 3786)
Email: festo.canada@ca.festo.com

Technical Support:
Tel: 1 866 GO FESTO (1 866 463 3786)
Fax: 1 877 FX FESTO (1 877 393 3786)
Email: technical.support@ca.festo.com

USA Customers

Commercial Support:
Tel: 1 800 99 FESTO (1 800 993 3786)
Fax: 1 800 96 FESTO (1 800 963 3786)
Email: customer.service@us.festo.com

Technical Support:
Tel: 1 866 GO FESTO (1 866 463 3786)
Fax: 1 800 96 FESTO (1 800 963 3786)
Email: product.support@us.festo.com