

Guide axes ELFC, without drive



Guide axes ELFC, without drive

Key features

At a glance

- Driveless linear guide units with guide and freely movable slide
- The guide axis is designed to support force and torque capacity in multi-axis applications
- Higher torsional resistance
- Reduced vibrations with dynamic loads
- Drive axis and guide axis can be placed adjacent to or above one another

Characteristic values of the axes

The specifications shown in the table are maximum values.

The precise values for each of the variants can be found in the relevant technical data section.

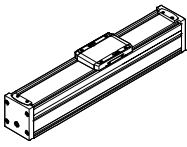
Version	Can be combined with	Size	Working stroke [mm]	Guide characteristics						
				Forces and torques						
				Fy [N]	Fz [N]	Mx [Nm]	My [Nm]	Mz [Nm]		
Recirculating ball bearing guide										
	Toothed belt axis ELGC-TB-KF Spindle axis ELGC-BS-KF	32	100, 200, 300, 400, 500, 600, 800	356	356	1.3	1.1	1.1		
		45	100, 200, 300, 400, 500, 600, 800, 1000, 1200, 1500	880	880	5.5	4.7	4.7		
		60	100, 200, 300, 400, 500, 600, 800, 1000, 1200, 1500, 1800, 2000	3641	3641	29.1	31.8	31.8		
		80	100, 200, 300, 400, 500, 600, 800, 1000, 1200, 1500, 1800, 2000	5543	5543	59.8	56.2	56.2		

Guide axes and the corresponding axes

Guide axis EGC-FA



- Can be combined with:
 - Toothed belt axis EGC-TB
 - Spindle axis EGC-BS
- For size 70 ... 185
- Load capacity up to max. 15200 N or 1157 Nm

Guide axis ELFA



- Can be combined with:
 - Toothed belt axis ELGA-TB-KF, ELGA-TB-RF
 - Spindle axis EGC-BS-KF
- For size 70 ... 120
- Load capacity up to max. 6890 N or 680 Nm

Guide axis ELFR



- Can be combined with:
 - Toothed belt axis ELGR
- For size 35 ... 55
- Load capacity up to max. 300 N or 124 Nm

Guide axis DGC-FA



- Can be combined with:
 - Linear drive DGC-KF
- For size 8 ... 63
- Load capacity up to max. 15200 N or 1157 Nm

Guide axes ELFC, without drive

Key features

Combination matrix between axis ELGC-TB, ELGC-BS, mini slide EGSC-BS and guide axis ELFC

With profile mounting EAHF-L2-...-P-D...

- For axis/axis mounting without adapter plate
- Mounting option: base axis with the next smallest assembly axis

	Size	Assembly axis ELGC-BS/-TB; ELFC; EGSC-BS			
		25	32	45	60
Base axis	32	■	–	–	–
ELGC-BS/-TB; ELFC	45	–	■	–	–
	60	–	–	■	–
	80	–	–	–	■

Sample applications

Toothed belt axis ELGC-TB – Mini slide EGSC-BS

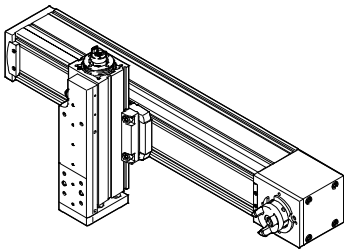

Spindle axis ELGC-BS – Mini slide EGSC-BS

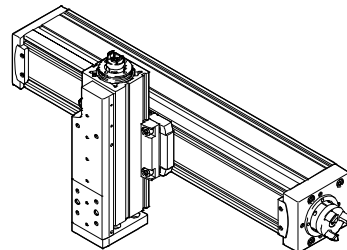

Toothed belt axis ELGC-TB – Spindle axis ELGC-BS

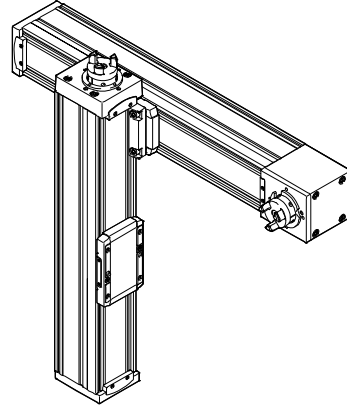
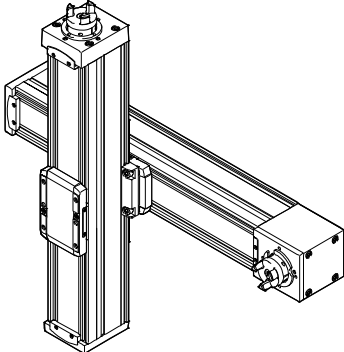

Guide axes ELFC, without drive

Key features

Combination matrix between axis ELGC-TB, ELGC-BS, mini slide EGSC-BS and guide axis ELFC

With adapter kit EHAA-D-L2

- For axis/axis mounting with adapter plate
- Mounting option: base axis with the same size or next smallest assembly axis
- When motors are assembled using parallel kits, interfering contours may occur. In this case, the adapter plate is required for height compensation (download CAD data → www.festo.com)

	Size	Assembly axis ELGC-BS/-TB; ELFC; EGSC-BS				
		25	32	45	60	80
Base axis	32		■	-	-	-
ELGC-BS/-TB; ELFC	45	-		■	-	-
	60	-	-		■	-
	80	-	-	-		■

Sample applications

Toothed belt axis ELGC-TB – Mini slide EGSC-BS

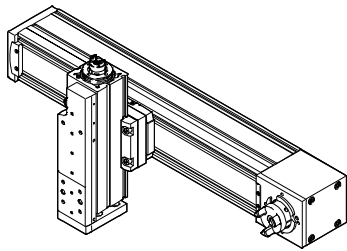

Spindle axis ELGC-BS – Mini slide EGSC-BS

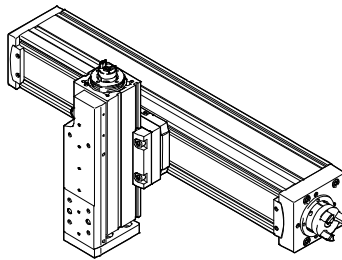

Toothed belt axis ELGC-TB – Spindle axis ELGC-BS

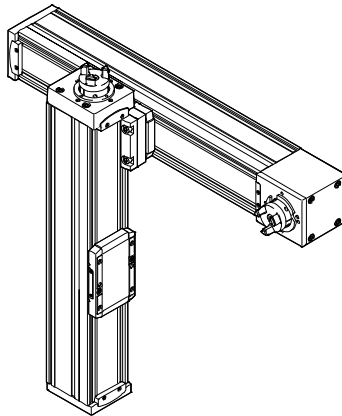
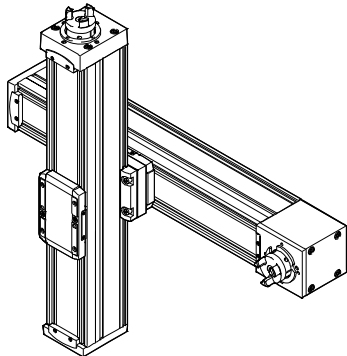

Guide axes ELFC, without drive

Key features

Combination matrix between axis ELGC-TB, ELGC-BS, mini slide EGSC-BS and guide axis ELFC

With angle kit EHAA-D-L2-...-AP

- For mounting the next smallest vertical axes (assembly axes) on base axes with mounting position “slide at top”

	Size	Assembly axis ELGC-BS/-TB; ELFC; EGSC-BS			
		25	32	45	60
Base axis	32	■	–	–	–
ELGC-BS/-TB; ELFC	45	–	■	–	–
	60	–	–	■	–
	80	–	–	–	■

Sample applications

Toothed belt axis ELGC-TB – Spindle axis ELGC-BS

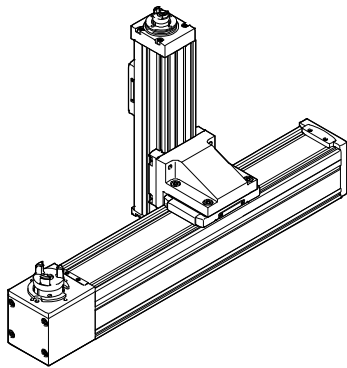

Toothed belt axis ELGC-TB – Mini slide EGSC-BS

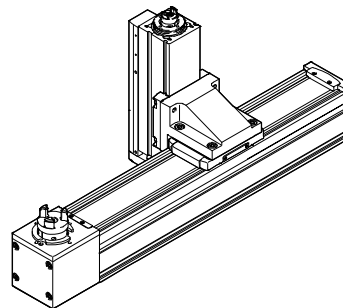

Spindle axis ELGC-BS – Mini slide EGSC-BS

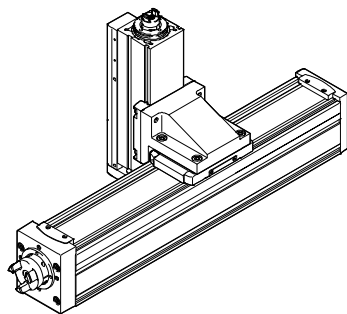

Guide axes ELFC, without drive

Type codes

		ELFC	-	KF	-	45	-	500
Type								
ELFC	Guide axis							
Guide								
KF	Recirculating ball bearing guide							
Size								
Stroke [mm]								

Guide axes ELFC, without drive

Peripherals overview

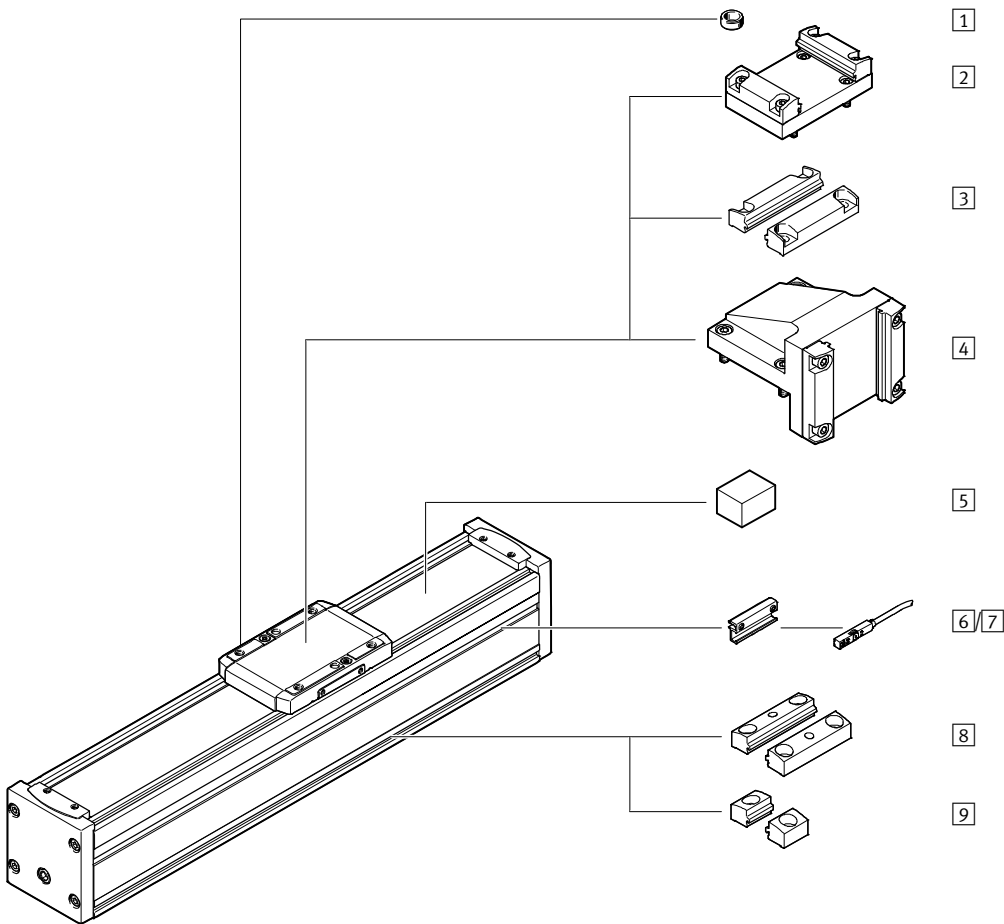



Accessories		
Type	Description	→ Page/Internet
1 Centring pin/sleeve ZBS/ZBH	For centring loads and attachments on the slide	22
2 Adapter kit EHAA-D-L2	<ul style="list-style-type: none"> For axis/axis mounting with adapter plate Mounting option: base axis with the same size or next smallest assembly axis (→ page 4) When motors are assembled using parallel kits, interfering contours may occur. In this case, the adapter plate is required for height compensation (download CAD data → www.festo.com) 	20
3 Profile mounting EAHF-L2-...-P-D...	<ul style="list-style-type: none"> For axis/axis mounting without adapter plate Mounting option: base axis with the next smallest assembly axis (→ page 3) 	19
4 Angle kit EHAA-D-L2-...-AP	For mounting the next smallest vertical axes (assembly axes) on base axes with mounting position “slide at top” (→ page 5)	21
5 Clamping element EADT-S-L5-32	Tool for retensioning the cover strip	22
6 Sensor bracket EAPM-L2-SH	For mounting the proximity sensors on the axis. The proximity sensors can only be mounted using the sensor bracket	22
7 Proximity sensor SMT-8M	Magnetic proximity sensor, for T-slot	23
8 Profile mounting EAHF-L2-...-P	For mounting the axis on the side of the profile. The profile mounting can be fixed in place on the mounting surface using the drill hole in the centre	18
9 Profile mounting EAHF-L2-...-P-S	For mounting the axis on the side of the profile	17

Guide axes ELFC, without drive

Technical data

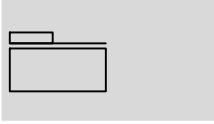
Function



-  Size
32 ... 80
-  Stroke length
100 ... 2000 mm



General technical data					
Size		32	45	60	80
Design		Guide			
Guide		Recirculating ball bearing guide			
Mounting position		Any			
Working stroke	[mm]	100, 200, 300, 400, 500, 600, 800	100, 200, 300, 400, 500, 600, 800, 1000, 1200, 1500	100, 200, 300, 400, 500, 600, 800, 1000, 1200, 1500, 1800, 2000	100, 200, 300, 400, 500, 600, 800, 1000, 1200, 1500, 1800, 2000
Max. displacement force	[N]	2	4.5	6.75	15
Max. speed	[m/s]	1.5			
Max. acceleration	[m/s ²]	15			

Operating and environmental conditions	
Ambient temperature	[°C] 0 ... +50
Degree of protection	IP40
Duty cycle	[%] 100
Maintenance interval	Life-time lubrication

Weight [g]					
Size		32	45	60	80
Basic weight with 0 mm stroke ¹⁾		168	384	1029	1905
Additional weight per 10 mm stroke		11	23	43	73
Moving load		61	144	407	815

1) Including slide

Materials

Sectional view

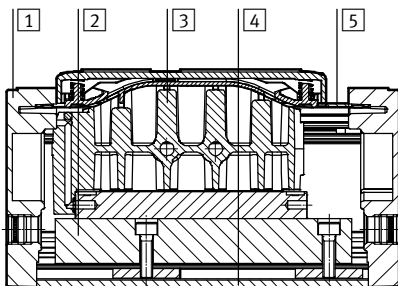

Axis		
1	End cap	Painted die-cast aluminium
2	Guide	Steel
3	Slide	Die cast aluminium
4	Profile	Anodised wrought aluminium alloy
5	Cover strip	High-alloy stainless steel
Note on materials		Contains paint-wetting impairment substances RoHS compliant

Guide axes ELFC, without drive

Technical data

Characteristic load values

The indicated forces and torques refer to the centre of the guide. The point of application of force is the point where the centre of the guide and the longitudinal centre of the slide intersect.

These values must not be exceeded during dynamic operation. Special attention must be paid to the cushioning phase.

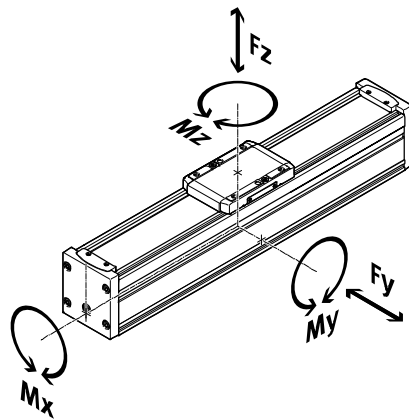

Distance from the slide surface to the centre of the guide

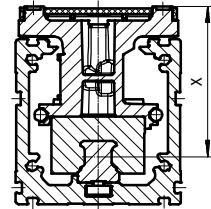

Max. permissible forces and torques on the slide (strength limits)					
Size		32	45	60	80
F _{y,max.}	[N]	150	300	600	900
F _{z,max.}	[N]	300	600	1800	2700
M _{x,max.}	[Nm]	1.3	5.5	29.1	59.8
M _{y,max.}	[Nm]	1.1	4.7	31.8	56.2
M _{z,max.}	[Nm]	1.1	4.7	31.8	56.2

Distance from the slide surface to the centre of the guide					
Size		32	45	60	80
Dimension x	[mm]	31.4	42.8	54.6	72.5

Max. permissible forces and torques for the bearing calculation, for a service life of 5000 km or 5 x 10 ⁶ cycles					
Size		32	45	60	80
F _{y,max.}	[N]	356	880	3641	5543
F _{z,max.}	[N]	356	880	3641	5543
M _{x,max.}	[Nm]	1.3	5.5	29.1	59.8
M _{y,max.}	[Nm]	1.1	4.7	31.8	56.2
M _{z,max.}	[Nm]	1.1	4.7	31.8	56.2

 Note

For a guide system to have a service life of 5000 km, the load comparison factor must have a value of $f_v < 1$, based on the maximum permissible forces and torques for a service life of 5000 km.

If the axis is subjected to two or more of the indicated forces and torques simultaneously, the following equation must be satisfied in addition to the indicated maximum loads:

Calculating the load comparison factor:

$$f_v = \frac{|F_{y,dyn}|}{F_{y,max}} + \frac{|F_{z,dyn}|}{F_{z,max}} + \frac{|M_{x,dyn}|}{M_{x,max}} + \frac{|M_{y,dyn}|}{M_{y,max}} + \frac{|M_{z,dyn}|}{M_{z,max}}$$

Guide axes ELFC, without drive

Technical data

Calculating the service life

The service life of the guide depends on the load. To be able to make a statement about the service life of the guide, the graph below plots the load comparison factor f_v against the service life.

These values are only theoretical. You must consult your local Festo contact for a load comparison factor f_v greater than 1.

Load comparison factor f_v as a function of service life l

Example:

A user wants to move an X kg load. Using the formula (→ page 9) gives a value of 1.5 for the load comparison factor f_v . According to the graph, the guide would have a service life of approx. 1500 km. Reducing the acceleration reduces the M_z and M_y values. A load comparison factor f_v of 1 now gives a service life of 5000 km.

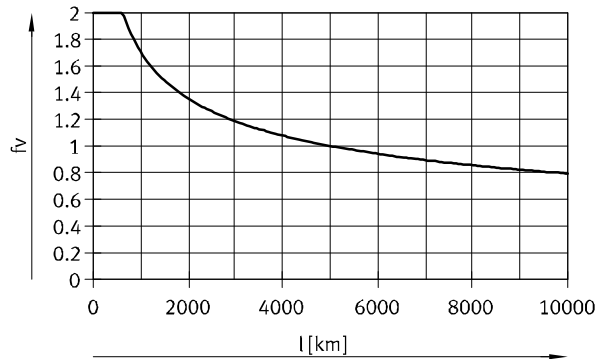

Comparison of the characteristic load values for 5000 km with dynamic forces and torques of recirculating ball bearing guides

The characteristic load values of roller guides are standardised to ISO and JIS using dynamic and static forces and torques. These forces and torques are based on an expected service life of the guide system of 100 km to ISO or 50 km to JIS. As the characteristic load values are dependent on the service life, the maximum permissible forces and torques for a 5000 km service life cannot be compared with the dynamic forces and torques of roller guides to ISO/JIS.

To make it easier to compare the guide capacity of linear axes ELFC with roller guides, the table below lists the theoretically permissible forces and torques for a calculated service life of 100 km. This corresponds to the dynamic forces and torques to ISO.

These 100 km values have been calculated mathematically and are only to be used for comparing with dynamic forces and torques to ISO. The drives must not be loaded with these characteristic values as this could damage the axes.

Max. permissible forces and torques for a theoretical service life of 100 km (from a guide perspective only)					
Size		32	45	60	80
$F_{y_{max}}$	[N]	1310	3240	13400	20400
$F_{z_{max}}$	[N]	1310	3240	13400	20400
$M_{x_{max}}$	[Nm]	5	20	107	220
$M_{y_{max}}$	[Nm]	4	17	117	207
$M_{z_{max}}$	[Nm]	4	17	117	207

Guide axes ELFC, without drive

Technical data

2nd moment of area

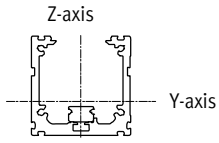

Size		32	45	60	80
I_y	[mm ⁴]	38×10^3	140×10^3	441×10^3	1.37×10^6
I_z	[mm ⁴]	45×10^3	170×10^3	542×10^3	1.66×10^6

Maximum permissible support spacing L (without profile mounting) as a function of force F

In order to limit deflection in the case of large strokes, the axis may need to be supported.

The following graphs can be used to determine the maximum permissible support spacing L as a function of force F acting on the axis. The deflection is $f = 0.5$ mm.

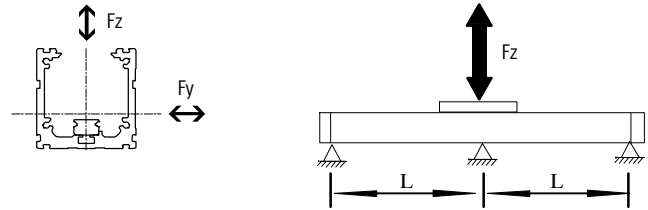

No support spacings are required for size 32.

Force F_y
Size 45

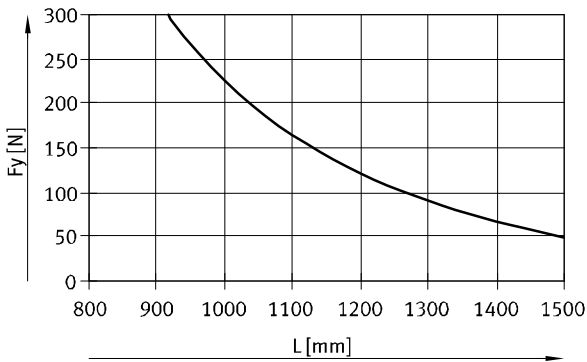

Size 60/80

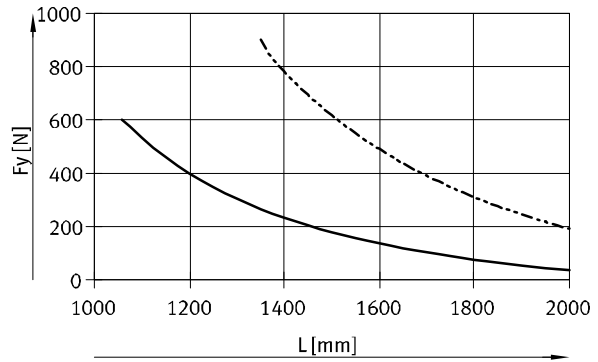

Force F_z
Size 45

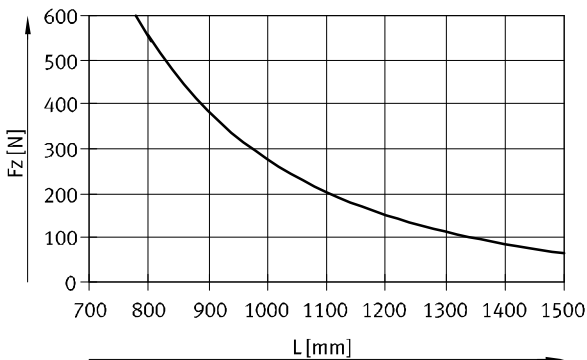

Size 60/80

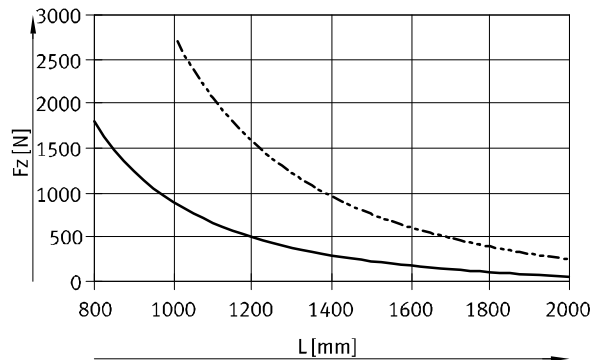

— ELFC-KF-45

— ELFC-KF-60
- - - ELFC-KF-80

Recommended deflection limits

Adherence to the following deflection limits is recommended so as not to impair the functional performance of the axes. Greater deformation can result in increased friction, greater wear and reduced service life.

Size	Dynamic deflection (moving load)	Static deflection
32 ... 80	0.05% of the axis length, max. 0.5 mm	0.1% of the axis length

Guide axes ELFC, without drive

Technical data

Dimensions

Download CAD data → www.festo.com

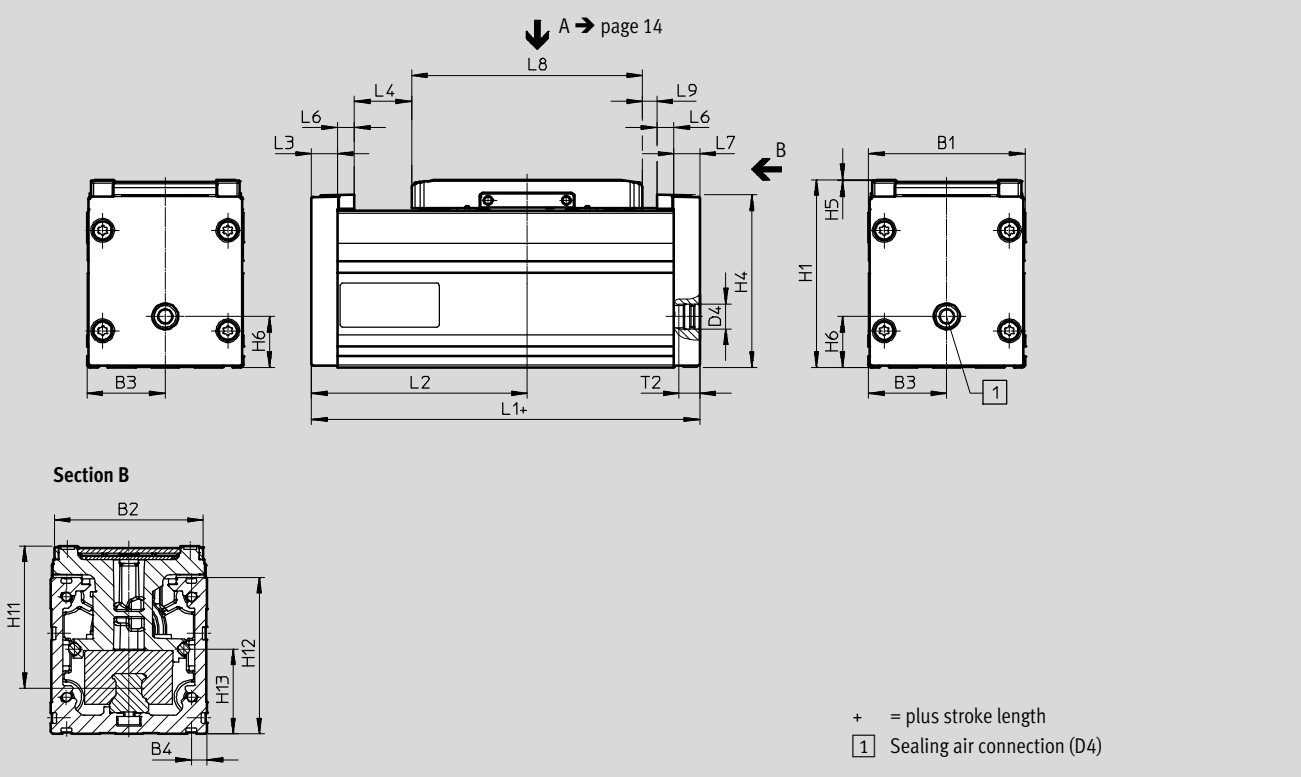

Size	B1	B2	B3	B4	D4	H1	H4	H5	H6	H11	H12
32	32	29.6	16	4.9	M5	38.5	35.6	0.3	8	31.4	32
45	45	42.6	22.5	6.1	G1/8	54	49.6	0.5	12.5	42.8	45
60	60	57.1	30	6.1	G1/8	72	66.1	0.5	19.5	54.6	60
80	80	77.1	40	6.1	G1/8	96	88.1	0.5	20	72.5	80

Size	H13	L1	L2	L3	L4	L6	L7	L8	L9	T2
			Min.		Min.				Min.	
32	13.7	87	40.5	5	1.5	4.5	5	59	7.5	5.5
45	18.5	103.5	48.8	7	0	6.5	7	67.5	7.5	8
60	32.5	130.5	62.3	10	0	6.5	10	88.5	7.5	8
80	41.5	152	73	12	0	6.5	12	106	7.5	8

Guide axes ELFC, without drive

Technical data

Dimensions

Download CAD data → www.festo.com

Profile

Size 32

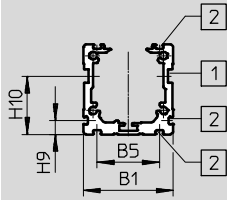

Size 45

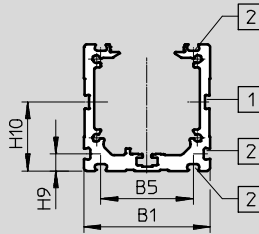

Size 60

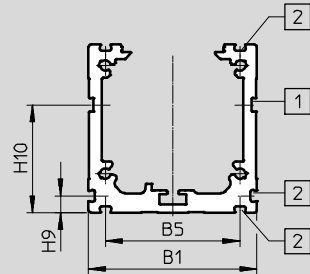

Size 80

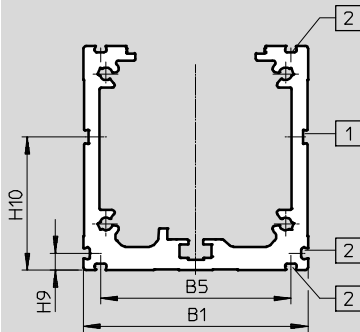

- 1 Slot for sensor bracket
- 2 Mounting slot

Size	B1	B5	H9	H10
32	32	22.2	4.9	20.8
45	45	32.9	6.1	24.5
60	60	47.9	6.1	38.5
80	80	67.9	6.1	47.5

Guide axes ELFC, without drive

Technical data

Dimensions

Download CAD data → www.festo.com

Slide

Size 32
View A

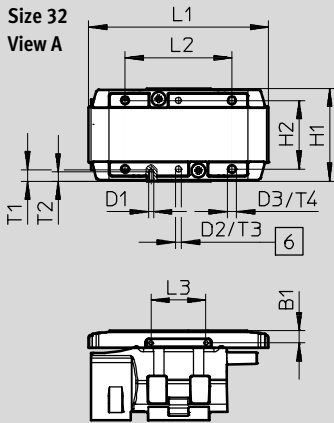

Size 45
View A

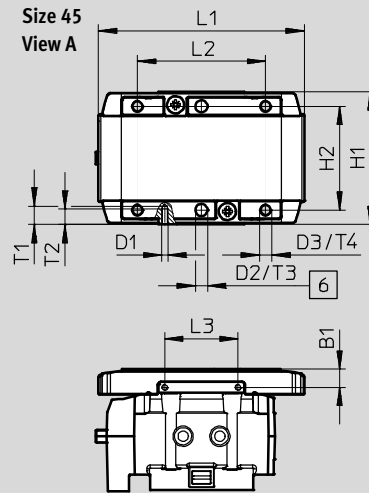

6 Hole for centring pin ZBS

Size	B1 ±0.1	D1	D2 ∅ H8	D3	H1 ±0.1	H2 ±0.1 for D2 ±0.03
32	4	M1.6	2	M3	30.5	22.5
45	6	M2	4	M4	43.5	34

Size	L1	L2 ±0.1	L3 ±0.1	T1	T2	T3 +0.1	T4 ¹⁾
32	59	35	18	3.8	3	3.1	4 ... 5
45	67.5	42	24	6	5	3.1	6 ... 7.5

1) Recommended screw-in depth

Guide axes ELFC, without drive

Technical data

Dimensions

Download CAD data → www.festo.com

Slide

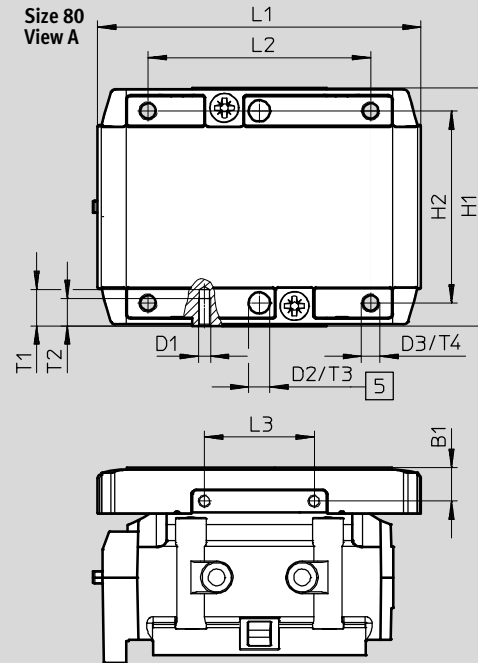
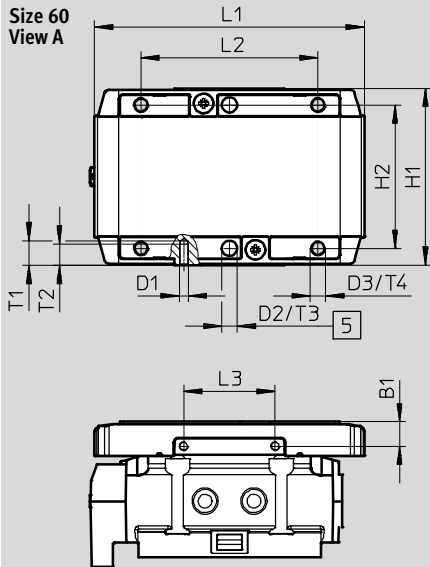

5 Hole for centring sleeve ZBH

Size	B1 ±0.1	D1	D2 ∅ H8	D3	H1 ±0.1	H2 ±0.1 for D2 ±0.03
60	8	M3	5	M5	58	47
80	11	M4	7	M6	78	63

Size	L1	L2 ±0.1	L3 ±0.1	T1	T2	T3 +0.1	T4 ¹⁾
60	88.5	58	30	9	7	1.3	8.5 ... 10
80	106	73	36	12	9	1.6	11 ... 14

1) Recommended screw-in depth

Guide axes ELFC, without drive

Technical data

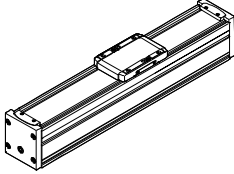
Ordering data				
	Size	Stroke [mm]	Part No.	Type
	32	100	8062796	ELFC-KF-32-100
		200	8062797	ELFC-KF-32-200
		300	8062798	ELFC-KF-32-300
		400	8062799	ELFC-KF-32-400
		500	8062800	ELFC-KF-32-500
		600	8062801	ELFC-KF-32-600
		800	8062876	ELFC-KF-32-800
	45	100	8062802	ELFC-KF-45-100
		200	8062803	ELFC-KF-45-200
		300	8062804	ELFC-KF-45-300
		400	8062805	ELFC-KF-45-400
		500	8062806	ELFC-KF-45-500
		600	8062807	ELFC-KF-45-600
		800	8062808	ELFC-KF-45-800
		1000	8062809	ELFC-KF-45-1000
	60	200	8062813	ELFC-KF-60-200
		300	8062814	ELFC-KF-60-300
		400	8062815	ELFC-KF-60-400
		500	8062816	ELFC-KF-60-500
		600	8062817	ELFC-KF-60-600
		800	8062818	ELFC-KF-60-800
		1000	8062819	ELFC-KF-60-1000
		1200	8062820	ELFC-KF-60-1200
		1500	8062821	ELFC-KF-60-1500
		1800	8062822	ELFC-KF-60-1800
		2000	8062823	ELFC-KF-60-2000
	80	100	8062824	ELFC-KF-80-100
		200	8062825	ELFC-KF-80-200
		300	8062826	ELFC-KF-80-300
		400	8062827	ELFC-KF-80-400
		500	8062828	ELFC-KF-80-500
		600	8062829	ELFC-KF-80-600
		800	8062830	ELFC-KF-80-800
		1000	8062831	ELFC-KF-80-1000
		1200	8062832	ELFC-KF-80-1200
1500		8062833	ELFC-KF-80-1500	
1800		8062834	ELFC-KF-80-1800	
2000		8062835	ELFC-KF-80-2000	

Guide axes ELFC, without drive

Accessories

Profile mounting EAHF-L2-...-P-S

Material:

Anodised wrought aluminium alloy

RoHS compliant

- For mounting the axis on the side of the profile

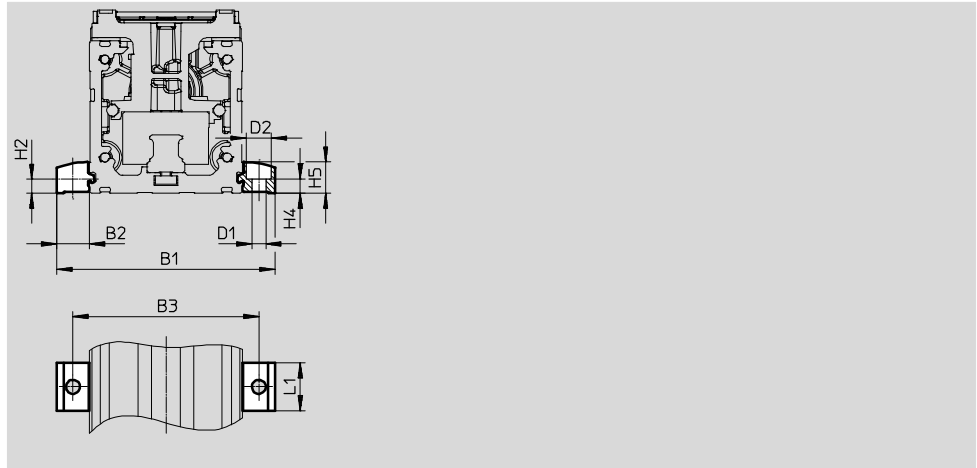

Dimensions and ordering data						
For size	B1	B2	B3	D1 ∅ H13	D2 ∅ H13	H2
32	51.4	9.7	42	4.5	8	4.9
45	70.6	12.8	58	5.5	10	6.1
60	85.6	12.8	73	5.5	10	6.1
80	105.6	12.8	93	5.5	10	6.1

For size	H4 ±0.1	H5	L1	Weight [g]	Part No.	Type
32	4.2	9	19	4	5183153	EAHF-L2-25-P-S
45	5.5	12.2	19	6	5184133	EAHF-L2-45-P-S
60	5.5	12.2	19	6	5184133	EAHF-L2-45-P-S
80	5.5	12.2	19	6	5184133	EAHF-L2-45-P-S

Guide axes ELFC, without drive

Accessories

Profile mounting EAHF-L2-...-P

Material:

Anodised wrought aluminium alloy

RoHS compliant

- For mounting the axis on the side of the profile.

The profile mounting can be fixed in place on the mounting surface using the drill hole in the centre.

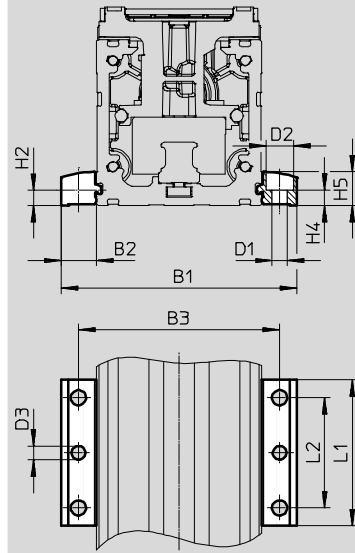

Dimensions and ordering data							
For size	B1	B2	B3	D1 Ø H13	D2 Ø H13	D3 Ø	H2
32	51.4	9.7	42	4.5	8	4	4.9
45	70.6	12.8	58	5.5	10	5	6.1
60	85.6	12.8	73	5.5	10	5	6.1
80	105.6	12.8	93	5.5	10	5	6.1

For size	H4 ±0.1	H5	L1	L2	Weight [g]	Part No.	Type
32	4.2	9	53	40	19	4835684	EAHF-L2-25-P
45	5.5	12.2	53	40	35	4835728	EAHF-L2-45-P
60	5.5	12.2	53	40	35	4835728	EAHF-L2-45-P
80	5.5	12.2	53	40	35	4835728	EAHF-L2-45-P

Guide axes ELFC, without drive

Accessories

Profile mounting EAHF-L2-...-P-D...

Material:

Anodised wrought aluminium alloy

RoHS compliant

- For axis/axis mounting without adapter plate
- Mounting option: base axis with the next smallest assembly axis down
(→ page 3)

Combination matrix					
Size		[2] Assembly axis ELGC-BS/-TB; ELFC; EGSC-BS			
		25	32	45	60
[1] Base axis ELGC-BS/-TB; ELFC	32	4759753	–	–	–
	45	–	4759748	–	–
	60	–	–	4759739	–
	80	–	–	–	4759726

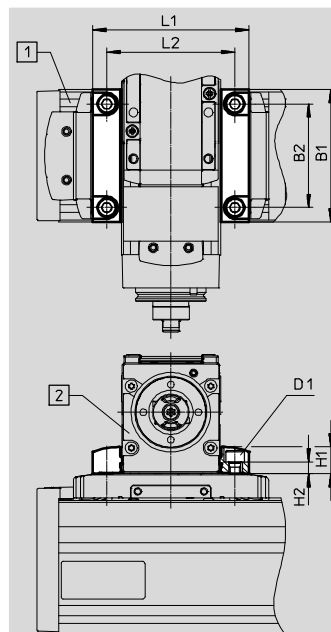

- [1] Base axis
- [2] Assembly axis

Dimensions and ordering data				
For combination (size)	B1	B2	D1	H1
32/25	32	22.5	M3	9
45/32	45	34	M4	9
60/45	60	47	M5	12.2
80/60	78	63	M6	12.2

For combination (size)	H2 ±0.1	L1	L2	Weight [g]	Part No.	Type
32/25	5.1	44.4	35	16	4759753	EAHF-L2-25-P-D1
45/32	3.7	51.4	42	24	4759748	EAHF-L2-25-P-D2
60/45	5.5	70.6	56	56	4759739	EAHF-L2-45-P-D3
80/60	4.5	85.6	73	77	4759726	EAHF-L2-45-P-D4

Guide axes ELFC, without drive

Accessories

Adapter kit EHAA-D-L2

Material:

Anodised wrought aluminium alloy

RoHS compliant

- For axis/axis mounting with adapter plate
- Mounting option: base axis with the same size or next smallest assembly axis (→ page 4)
- When motors are assembled using parallel kits, interfering contours may occur. In this case, the adapter plate is required for height compensation (download CAD data → www.festo.com)

Combination matrix					
Size	2 Assembly axis ELGC-BS/-TB; ELFC; EGSC-BS				
	25	32	45	60	80
1 Base axis	32	8066713		-	-
ELGC-BS/-TB; ELFC	45	-	8066714		-
	60	-	-	8066715	
	80	-	-	-	8066716

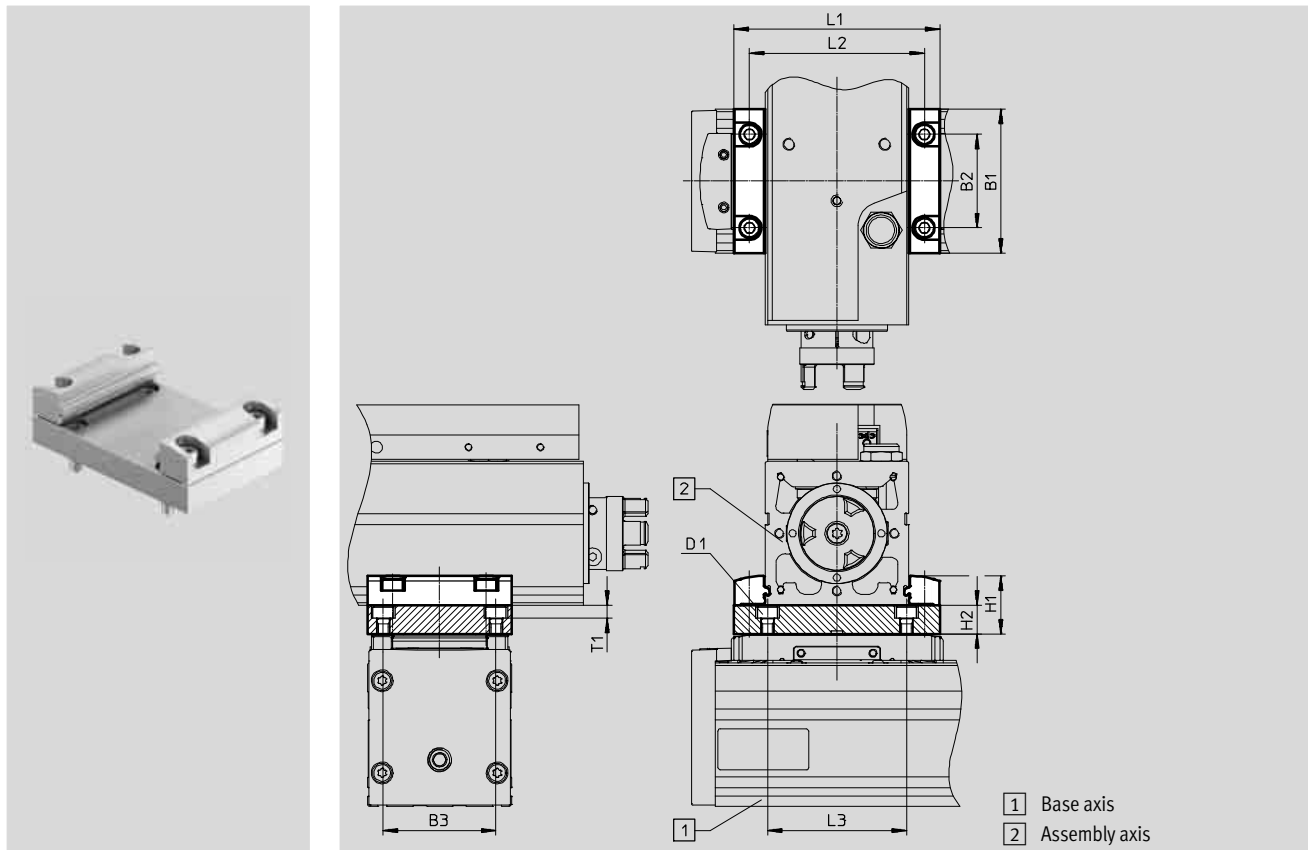

Dimensions and ordering data												
For combination (size)	B1	B3 ±0.05	D1	H1	H2	L1	L2	L3	T1	Weight [g]	Part No.	Type
32/25	32	22.5	M3	19	10	44.4	35	35	4.2	60	8066713	EHAA-D-L2-32-L2-32
45/32	45	34	M4	19	10	51.4	42	42	5.4	136	8066714	EHAA-D-L2-45-L2-45
60/45	60	47	M5	24.2	12	70.6	58	58	5.4	205	8066715	EHAA-D-L2-60-L2-60
80/60	78	63	M6	24.2	12	85.6	73	73	6.4	315	8066716	EHAA-D-L2-80-L2-80

For combination (size)	B1	B2	B3 ±0.05	D1	H1	H2	L1	L2	L3	T1	Weight [g]	Part No.	Type
32/32	32	14.5	22.5	M3	19	10	52	42	35	4.2	60	8066713	EHAA-D-L2-32-L2-32
45/45	45	32	34	M4	22.2	10	71	58	42	5.4	136	8066714	EHAA-D-L2-45-L2-45
60/60	60	39	47	M5	24.2	12	86	73	58	5.4	205	8066715	EHAA-D-L2-60-L2-60
80/80	78	63	63	M6	24.2	12	106	93	73	6.4	315	8066716	EHAA-D-L2-80-L2-80

Guide axes ELFC, without drive

Accessories

Angle kit EHAA-D-L2-...-AP

Material:

Anodised wrought aluminium alloy

RoHS compliant

- For mounting the next smallest vertical axes (assembly axes) on base axes with mounting position “slide at top” (→ page 5)

Combination matrix		2 Assembly axis ELGC-BS/-TB; ELFC; EGSC-BS			
Size		25	32	45	60
1 Base axis ELGC-BS/-TB; ELFC	32	8066717	-	-	-
	45	-	8066718	-	-
	60	-	-	8066719	-
	80	-	-	-	8066720



- 1 Base axis
- 2 Assembly axis

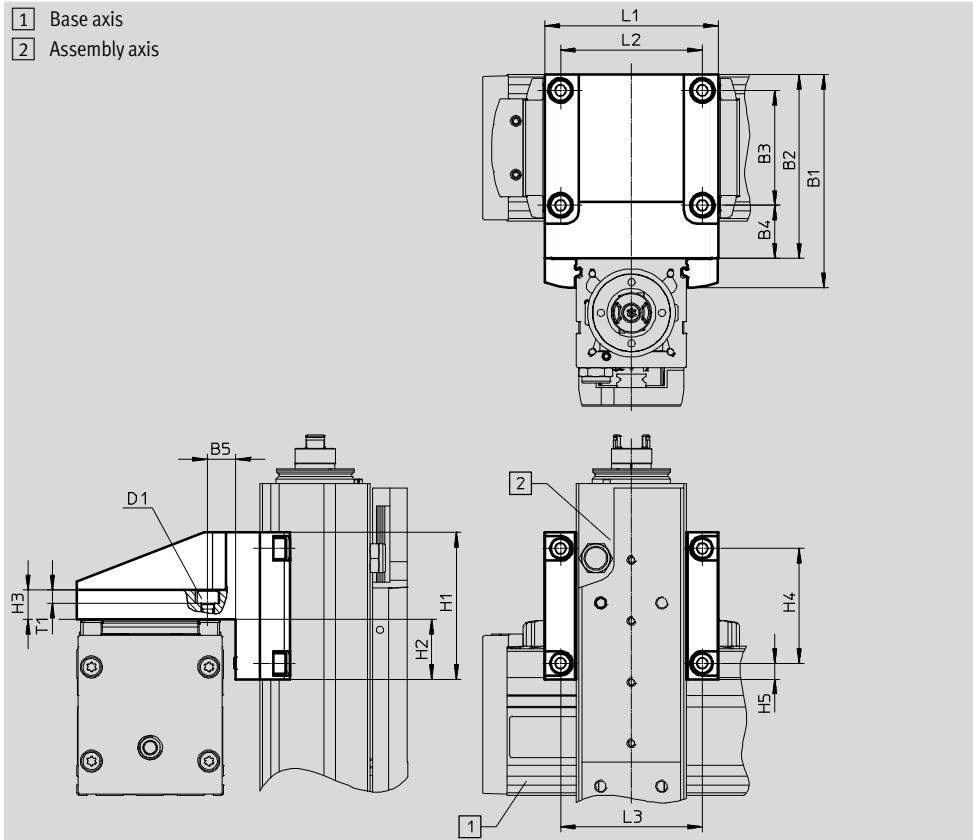

Dimensions and ordering data									
For combination (size)	B1	B2	B3	B4	B5	D1	H1	H2	H3
32	53	44	22.5	16.8	8.8	M3	32	11	10
45	69	60	34	20.5	11.5	M4	45	17.5	10
60	87.2	75	47	21.5	11.5	M5	60	24.5	12
80	107.2	95	63	23.5	13.5	M6	78	33.5	12

For combination (size)	H4	H5	L1	L2	L3	T1	Weight [g]	Part No.	Type
32	22.5	4.8	45	35	35	4.2	107	8066717	EHAA-D-L2-32-L2-25-AP
45	34	5.5	52	42	42	5.4	222	8066718	EHAA-D-L2-45-L2-32-AP
60	47	6.5	71	58	58	5.4	433	8066719	EHAA-D-L2-60-L2-45-AP
80	63	7.5	86	73	73	6.4	768	8066720	EHAA-D-L2-80-L2-60-AP

Guide axes ELFC, without drive

Accessories

Sensor bracket EAPM-L2-SH

Material:
Anodised wrought aluminium alloy
RoHS compliant

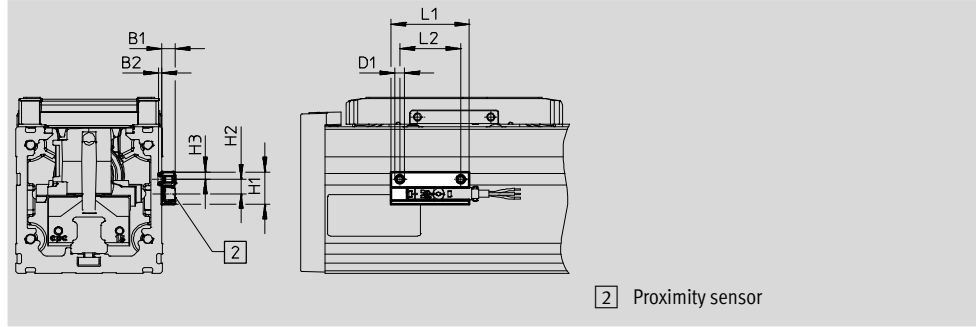



2 Proximity sensor

Dimensions and ordering data

For size	B1	B2	D1	H1	H2
32, 45, 60, 80	5.5	1.3	M4	13.4	6

For size	H3	L1	L2	Weight [g]	Part No.	Type
32, 45, 60, 80	3	32	25	4	4759852	EAPM-L2-SH

Ordering data



	For size	Description	Part No.	Type	PU ¹⁾
Centring pin ZBS/centring sleeve ZBH					
	32	For slide	525273	ZBS-2	10
	45		562959	ZBS-4	
	60		189652	ZBH-5	
	80		186717	ZBH-7	
Clamping element EADT					
	32, 45	Tool for retensioning the cover band	8065818	EADT-S-L5-32	1
	60, 80		8058451	EADT-S-L5-70	

1) Packaging unit quantity

Guide axes ELFC, without drive

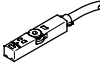
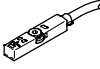
Accessories

Ordering data – Proximity sensor for T-slot, magneto-resistive					Technical data → Internet: smt	
	Type of mounting	Switching output	Electrical connection	Cable length [m]	Part No.	Type
N/O						
	Inserted in the slot from above, flush with the cylinder profile, short design	PNP	Cable, 3-wire	2.5	574335	SMT-8M-A-PS-24V-E-2,5-OE
			Plug connector M8x1, 3-pin	0.3	574334	SMT-8M-A-PS-24V-E-0,3-M8D
N/C						
	Inserted in the slot from above, flush with the cylinder profile, short design	PNP	Cable, 3-wire	7.5	574340	SMT-8M-A-PO-24V-E-2,5-OE

Ordering data – Connecting cables				Technical data → Internet: nebu	
	Electrical connection, left	Electrical connection, right	Cable length [m]	Part No.	Type
	Straight socket, M8x1, 3-pin	Cable, open end, 3-wire	2.5	541333	NEBU-M8G3-K-2.5-LE3
			5	541334	NEBU-M8G3-K-5-LE3
	Angled socket, M8x1, 3-pin	Cable, open end, 3-wire	2.5	541338	NEBU-M8W3-K-2.5-LE3
			5	541341	NEBU-M8W3-K-5-LE3

Festo North America

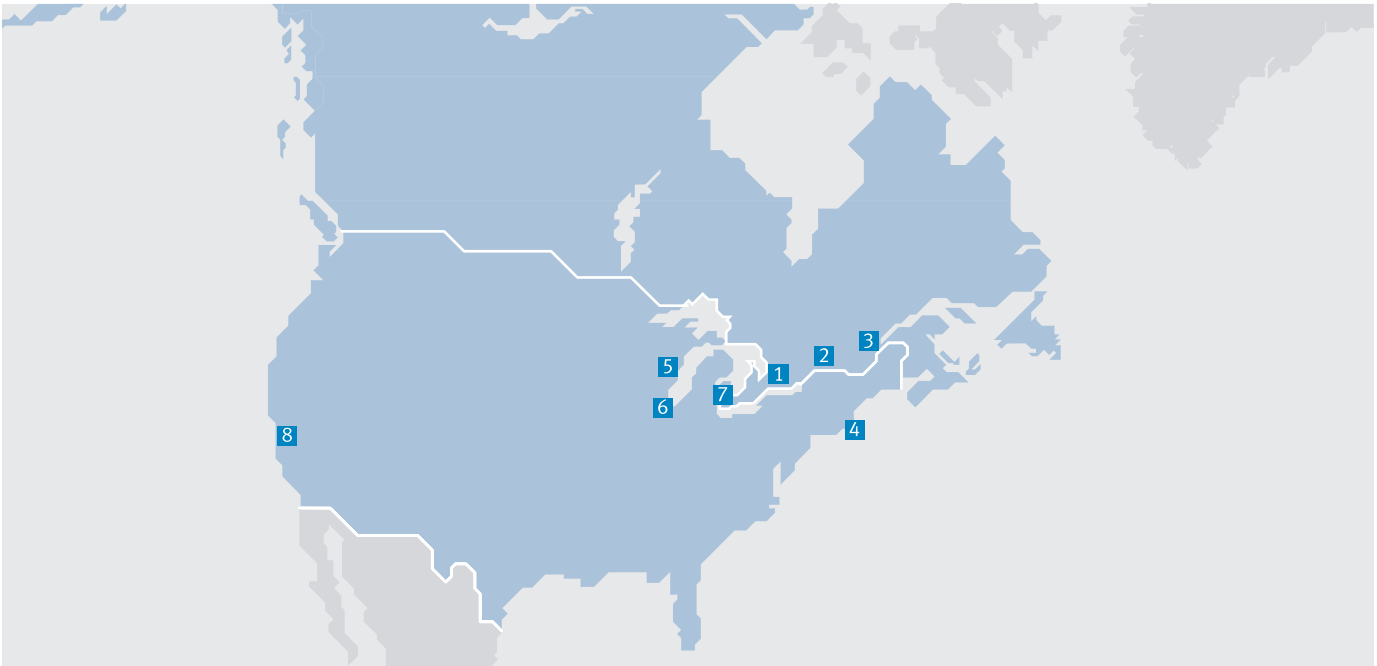

**1 Festo Canada
Headquarters
Festo Inc.**
5300 Explorer Drive
Mississauga, ON
L4W 5G4

2 Montréal
5600, Trans-Canada
Pointe-Claire, QC
H9R 1B6

3 Québec City
2930, rue Watt#117
Québec, QC
G1X 4G3



**4 Festo United States
Headquarters
Festo Corporation**
395 Moreland Road
Hauppauge, NY
11788

5 Appleton
North 922 Tower View Drive, Suite N
Greenville, WI
54942

7 Detroit
1441 West Long Lake Road
Troy, MI
48098

6 Chicago
85 W Algonquin - Suite 340
Arlington Heights, IL
60005

8 Silicon Valley
4935 Southfront Road, Suite F
Livermore, CA
94550

Festo Regional Contact Center

Canadian Customers

Commercial Support:
Tel: 1 877 GO FESTO (1 877 463 3786)
Fax: 1 877 FX FESTO (1 877 393 3786)
Email: festo.canada@ca.festo.com

Technical Support:
Tel: 1 866 GO FESTO (1 866 463 3786)
Fax: 1 877 FX FESTO (1 877 393 3786)
Email: technical.support@ca.festo.com

USA Customers

Commercial Support:
Tel: 1 800 99 FESTO (1 800 993 3786)
Fax: 1 800 96 FESTO (1 800 963 3786)
Email: customer.service@us.festo.com

Technical Support:
Tel: 1 866 GO FESTO (1 866 463 3786)
Fax: 1 800 96 FESTO (1 800 963 3786)
Email: product.support@us.festo.com

Subject to change

Internet: www.festo.com/us