

# HAITIMA

## Instruction Manual

### 3-Way Ball Valve

2057ND 1000 WOG

HIM-130 Version: A



Office : 8F, No.201, Tiding Blvd. Sec.2, Taipei, 114, Taiwan Web-site: [www.haitima.com.tw](http://www.haitima.com.tw)

Fax: +886-2-2658-3830 , 2658-2266 Tel:+886-2-2658-5800 E-mail: [haitima@seed.net.tw](mailto:haitima@seed.net.tw)

VZBE...T-63-F-3.../8068829/1701



3-Way Ball Valve  
2057ND 1000 WOG

Version

A

Document No.

HIM-130

Date

Apr.20,2013

# CONTENTS

- 1. Introduction and Safety Information ..... 1
  - 1.1 Introduction ..... 1
  - 1.2 Safety Information ..... 1
- 2. General Precautions..... 2
  - 2.1 Material Selection ..... 2
  - 2.2 Pressure-Temperature Rating ..... 2
  - 2.3 Fluid Thermal Expansion ..... 2
  - 2.4 Direct Mounting Pad ..... 2
  - 2.5 Hydrostatic Test ..... 2
  - 2.6 Liquids with High Fluid Velocity ..... 3
  - 2.7 Throttling Service ..... 3
- 3. Storage and Preparation ..... 4
  - 3.1 Storage ..... 4
  - 3.2 Preparation ..... 4
- 4. Installation ..... 5
  - 4.1 Handling ..... 5
  - 4.2 Cleaning ..... 5
  - 4.3 Manual Operation..... 5
- 5. Maintenance and Repair ..... 6
  - 5.1 Maintenance Frequency ..... 6
  - 5.2 Adjustment of The Gland ..... 6

VZBE...T-63-F-3 / 8068829 / 1701



**3-Way Ball Valve  
2057ND 1000 WOG**

**Version**

**A**

Document No. HIM-130

Date

Apr.20,2013

5.3 Disassembly.....	6
5.4 Parts Inspection, Maintenance, and Replacement: .....	6
5.5 Assembly .....	7
6. Quality Assurance and Service .....	9
6.1 Quality Assurance .....	9
6.2 Service.....	9
7. Technical Parameters and Valve Structure .....	10
7.1 Specification List .....	10
7.2 Torque.....	10
7.3 Pressure-Temperature Ratings .....	11
7.4 Valve Structure.....	11

VZBF...T-63-E-3.../8068829/1701

		<b>3-Way Ball Valve 2057ND 1000 WOG</b>	<b>Version</b>	<b>A</b>
Document No.	HIM-130		Date	Apr.20,2013
			Page	1

## 1. INTRODUCTION AND SAFETY INFORMATION

### 1.1 INTRODUCTION

This manual has been prepared to serve as a guide to insure continuous satisfactory service and assist in restoring a valve to proper working condition.

It covers 3 way 1000 WOG with ISO 5211 direct mounting pad screw ends, socket/butt weld ends , and carbon steel, stainless steel ball valves.

The installation, storage, operation, inspection and repair, service problems, maintenance and preventive maintenance, quality assurance and service, technical parameters covering these valves are also included in this manual.

All these valves are widely used in water system, petroleum, chemical, power plant and allied industries.

### 1.2 SAFETY INFORMATION

The following general safety notices supplement the specific warnings and cautions appearing elsewhere in this manual. They are recommended precautions that must be understood and applied during operation and maintenance of the equipment covered herein.

- a. Always wear eye shields, gloves and overalls. Wear protective footwear and headgear.
- b. To avoid injury, never attempt disassembly while there are pressures either upstream, or downstream. Even when replacing packing rings, caution is necessary to avoid possible injury.
- c. Do not attempt to disassemble a valve while there is pressure in the line. Make sure both upstream and downstream pressures are removed. Disassemble with caution in the event all pressures have not been relieved.
- d. Prior to replacing packing rings remove all pressure from the valve.
- e. To prevent valve distortion, inefficient operation, or early maintenance problems, support piping on each side of the valve.
- f. Do not touch surface of valve on high temperature.
- g. Valves are not to be used with unstable fluids.
- h. If provided, the Locking device on the handle is to avoid improper use of the valve by unauthorized people. This can be locked with a patch lock.

VZBF...T-63-E-3.../8068829/1701

		<b>3-Way Ball Valve 2057ND 1000 WOG</b>	<b>Version</b>	<b>A</b>
Document No.	HIM-130		Date	Apr.20,2013
			Page	2

## 2. GENERAL PRECAUTIONS

### 2.1 MATERIAL SELECTION

The possibility of material deterioration in service and the need for periodic inspections is depended on the contained fluid. Carbide phase conversion to graphite, oxidation of ferrite materials, and decrease in ductility of carbon steels at low temperature (even in applications above 29°F) and susceptibility to inter-granular corrosion of austenitic materials or grain boundary attack of nickel-base alloys are among those items. Information about corrosion data is provided in this I.O.M, the user is requested to take attention or consideration to determine if the used materials are suitable for the application.

### 2.2 PRESSURE-TEMPERATURE RATING

The Pressure-Temperature rating, published by manufacturer is usually considered an appropriate guide to the maximum temperature and pressure those ball valves may withstand. The principle of pressure-temperature rating is depending on static pressure. For reference client can ask the valve distributor or manufacturer for assurance of suitability when ball valves are subjected to the following conditions:

- Valves are left closed for long periods of service under high-temperature or high-pressure service conditions
- Valves are operated frequently for long periods with high-temperature or high-pressure service conditions.

### 2.3 FLUID THERMAL EXPANSION

It is possible, with the ball in closed condition; the sealed cavity inside the valve body is filled with liquid. If this liquid is not released, by partially opening the valve, and the valve is subject to a temperature increase, excessive pressure can occur inside the body. These HAITIMA ball valves have self-relieving pressure seats to prevent pressure built up. Our client is recommended to prevent a pressure build-up inside the valve exceeding the design pressure, by means of piping design, installation, or operation procedure.

### 2.4 DIRECT MOUNTING PAD

ISO 5211 direct mounting pad and stem orientation allows direct mounting for actuator to valves, no brackets and couplers are required, making automation a lot easier with improved performance.

### 2.5 HYDROSTATIC TEST

Before delivery, all valve body's are tested 1.5 times the working pressure in open position. After installation, the pipeline system may be subject to a system test not to exceed the above mention pressure.

**(For example: 1000 WOG is hydrostatic tested 1.5 X 1000 = 1500 psi testing pressure)**

VZBF...T-63-E-3.../8068829/1701

		<b>3-Way Ball Valve 2057ND 1000 WOG</b>	<b>Version</b>	<b>A</b>
Document No.	HIM-130		Date	Apr.20,2013
			Page	3

## 2.6 LIQUIDS WITH HIGH FLUID VELOCITY

When ball valves must be operated frequently on liquids with very high velocity, a check shall be made with the valve distributor or manufacturer for appropriate advice to minimize the possibility of seat deformation, especially when working pressure and temperature is reaching maximum ranges.

## 2.7 THROTTLING SERVICE

Standard ball valves are generally not recommended for throttling service. The fluid flow can damage the leading edge of the ball and/or damage or deform the resilient ball seats causing leakage. High fluid velocity and/or the presence of solid particles in the media will reduce the lifetime of seat and ball during throttling applications.



VZBE...T-63-E-3.../8068829/1701

		<b>3-Way Ball Valve 2057ND 1000 WOG</b>	<b>Version</b>	<b>A</b>
Document No.	HIM-130		Date	Apr.20,2013
			Page	4

### 3. STORAGE AND PREPARATION

#### 3.1 STORAGE

##### 3.1.1 Temporary Storage

If valves are to be stored before installation, the following should be observed.

- a. Keep the valves wrapped and protected as shipped from the manufacturer.
- b. Do not remove the plastic bag or protective end covering until the valve is ready for installation. This will reduce the possibility of foreign material damaging internal valve components.
- c. Valves stored outdoors should be positioned such that water dose not accumulate in the valve body.

##### 3.1.2 Long Term Storage

If the valves are to be stored more than of one year, they should be prepared in the following manner.

- a. Remove the packing and apply a preservative to the packing chamber.
- b. Do not remove the protective end covering.
- c. Valve which will remain in storage for an excessive period of time should have a preservative applied to the external surface.
- d. Do not store the valves outdoors.

#### 3.2 PREPARATION

- a. Remove the plastic bag or valve end protection (if any).
- b. Prior to shipment from the manufacturer, a preservative may have been applied to the inner body of the valve. This preservative maybe removed with a solvent.
- c. The inside of the valve should be inspected and blown out with compressed air. Adjacent piping must be clean and free from debris to prevent damage to the valve.
- d. To prevent valve distortion, inefficient operation or early maintenance problems, support piping on each side of the valve.
- e. Make sure the valve is positioned such that there is sufficient space so that the handle is easily and safely reached.
- f. The 3-way ball valves can be installed in any position without regard for the direction of the flow, unless marked in the flow direction.
- g. The 3-way ball valves are not designed for throttling and should be kept in the fully open or closed position. Should the valve be used in a partially open or closed position, the ball and seats may become eroded in a very short time. This may also cause a chatter noise in the line.

VZBE...T-63-E-3.../8068829/1701

		<b>3-Way Ball Valve</b> <b>2057ND 1000 WOG</b>		<b>Version</b>	<b>A</b>
				Date	Apr.20,2013
Document No.	HIM-130			Page	5

## 4. INSTALLATION

### 4.1 HANDLING

Make sure that the used lifting equipment is strong enough to ensure a safe installation.

### 4.2 CLEANING

Even the valves was transported under a clean environment, operator must check is there any foreign body or dusts inside the bore. If yes, clean it before installation. Operator clean the valves by water, compression air, or steam (automation valve shall be cleaned only with water or steam, the compression air is not allowed.)

### 4.3 MANUAL OPERATION

For manual operation, shift the handle in counter-clockwise and clockwise direction for diversions or mixing fluid.

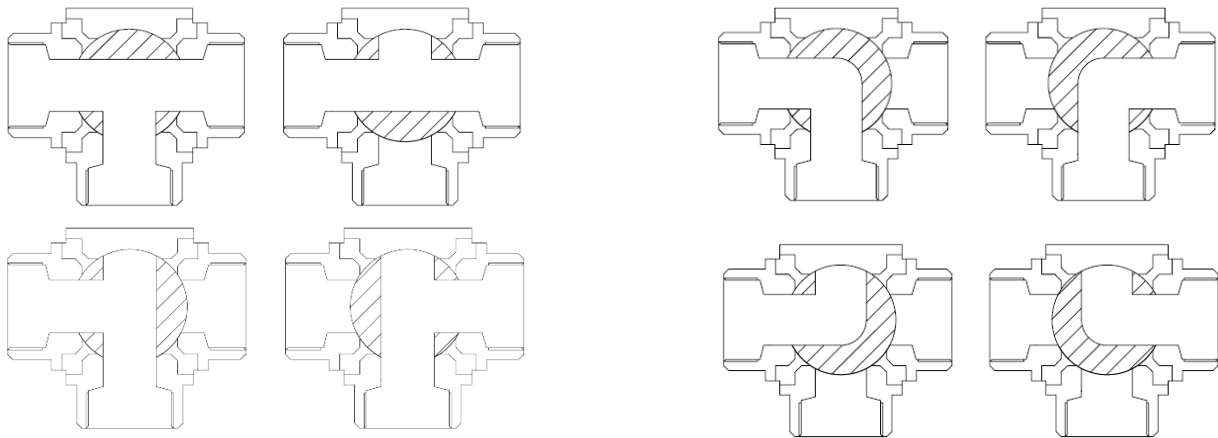

T-PORT

L-PORT

Table 1 - Flow Patterns for 3-Way ball Valve



VZBE...T-63-E-3.../8068829/1701



## 3-Way Ball Valve 2057ND 1000 WOG

**Version**

**A**

Date

Apr.20,2013

Document No.

HIM-130

Page

6

### 5. MAINTENANCE AND REPAIR

#### 5.1 MAINTENANCE FREQUENCY

The maintenance frequency is determined upon the application. User shall consider the time interval depend on the kinds of fluid, flow velocity, operation frequency, high-pressure effect and high-temperature effect etc.

#### 5.2 ADJUSTMENT OF THE GLAND

Tighten the gland nut about ¼ turn periodically to compensate for the wear caused by movement between stem and stem packing.

#### 5.3 DISASSEMBLY

**NOTE: If complete disassembly is necessary, replacement of all seats and seals is recommended.**

- a. To dismantle the valve must follow the procedure below.
- b. It doesn't matter where the position of valve located is; usually it contained the seal up fluid, so operator must be very carefully when moving the valve on the pipe. It must open the ball a little and let the fluid come out slowly, it also need to watch out the poisonous and inflammability objects if there is any.
- c. It must turn the ball in the close position before dismantle the valve. The ball cannot be taken out from valve body if the ball is in the open or semi-open position. The right position for store the valve is put the flange end on the ground. If it is a valve with the hand wheel, than it must dismantle the hand wheel from the valve first than put the valve flange end on the ground. This procedure is protecting the surface of the ball.
- d. To dismantle the valve body and end cap, release retainer with a special tool. It must be careful to dismantle the ball to avoid the seat retainer fall down from end cap.
- f. To lift the ball by hoist, it must make the protection on corner to avoid the ball damaged by metal contacted.

#### 5.4 PARTS INSPECTION, MAINTENANCE, AND REPLACEMENT:

- a. Check the surface of ball if it is scraped. Use the PT for inspection if necessary. If there is any damage on the surface, then find out the root cause such as the dirt fluid...etc. Avoid the damage factors as far as possible as we can.

VZBE...T-63-E-3.../8068829/1701

		<b>3-Way Ball Valve 2057ND 1000 WOG</b>		<b>Version</b>	<b>A</b>
				Date	Apr.20,2013
Document No.	HIM-130			Page	7

- b. The damage of the ball surface, to gauge if it is located on the contacting area of ball and ball seat. If it is the case, then the ball must take a fine milling. If it cause a heavy damaged, then it must welded and re-machined. If it cannot be repaired then change a new ball.
- c. If the scraped area is not at the location described in the item (2) above, then it must re-fine milling the damage area again. Otherwise, the ball will damage the soft seat during the open and close operation or it will dig out the ball seat and cause a heavy damage to ball and seat.
- d. Check the thickness of valve body and cap. As defined in section a. The body and cap material may wear because of the status of fluid. User should decide the frequency for checking thickness.
- e. To inspect the surface of soft seat, if there is it any scrap mark, concave, dust (including weld dregs, iron bit, sands...etc.), abrasion, abnormal press scrape, and a tiny scrap. Usually, the scrape mark and damage by dust will occur in the same time with ball damage. It is the root cause for leakage. If the leakage occurs before the repairing, then this is suggested to change a new soft seat (PTFE or RTFE). The mark from press or fine scrap happens in an abnormal operation pressure. It must be reconsider to choice a right valve.
- f. To check the worm gear if it can be operated correctly, the operated correctly means people can use one finger to turn the wheel. When the torque higher then 25KG-M, if must open the gear- box and check the connection of the tooth of gear. To check has there is any grease, spoiled grease, water, oxidation or dust in the box.
- g. Worm gear operator has a switch of open/close indicator get back to the original location after dismantle or assembly. It must do the pressure inspection before install onto pipe line; otherwise, it will become very difficult to do adjustment on the pipe line. The stem packing must be replaced by new parts after dismantle the valve. Its material has PTFE, Graphite and Carbon Fiber. The material of new packing must be the same as the old one. To tight the gland nut, it must pass the 1.5 times water pressure test without leakage. Do not make the gland nut too tight to avoid the higher torque.
- h. To do the final inspection for a valve, 10 times of open and close operating must be done to ensure all the parts are assembled correctly. To ensure the torque is in a same value during the open/close operation. If the torque is not the same in operation, then there may have some parts in an correct position or interference. Please dismantle and re-assembly. Otherwise, the valve will get damaged easily when working on pipeline under higher pressure.

## 5.5 ASSEMBLY

For assembly process, it takes the opposite way of dismantle process. The must in the close position during assembling the body and end cap, the stopper must be located at the right place; otherwise, the open and close operation will be opposite.

VZBE...T-63-F-3.../8068829/1701

**3-Way Ball Valve**  
**2057ND 1000 WOG**

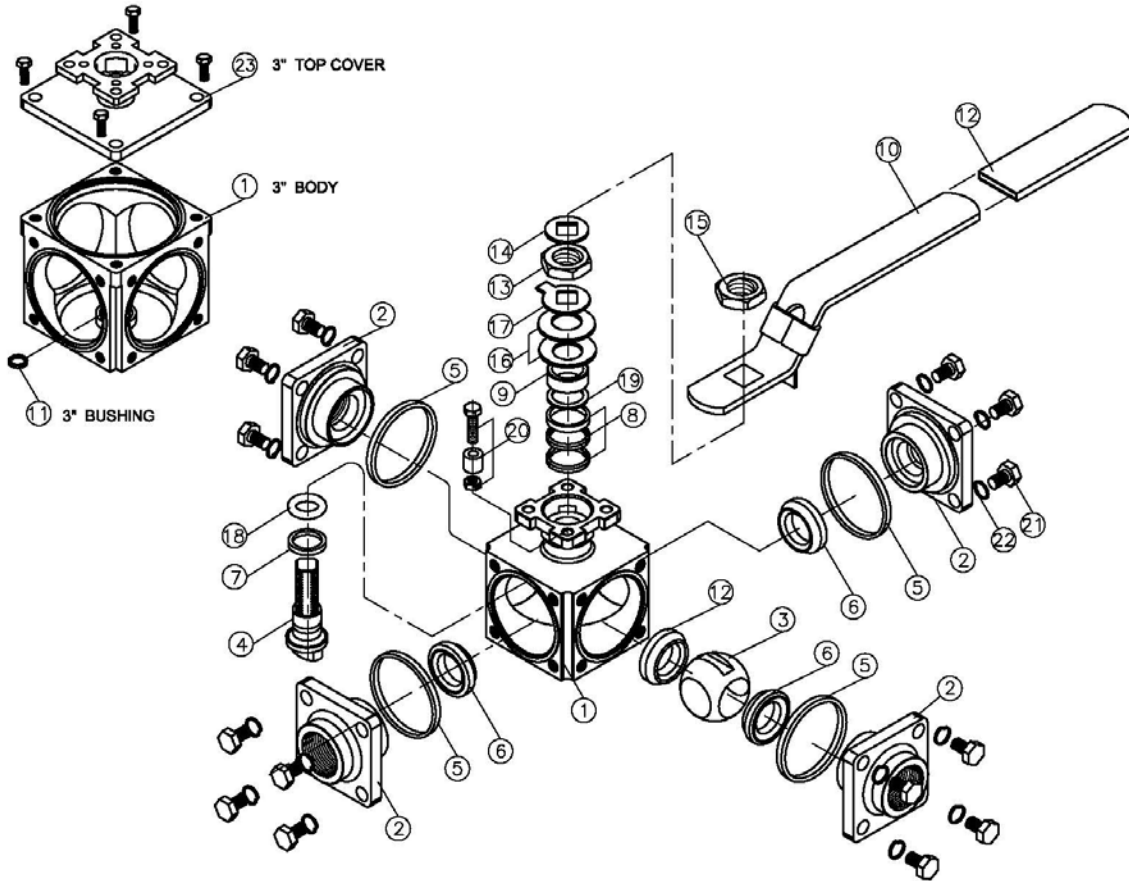

VZBE...T-63-E-3.../8068829/1701

		<b>3-Way Ball Valve 2057ND 1000 WOG</b>	<b>Version</b>	<b>A</b>
Document No.	HIM-130		Date	Apr.20,2013
			Page	9

## 6. QUALITY ASSURANCE AND SERVICE

### 6.1 QUALITY ASSURANCE

HAITIMA's warrants its products to be free from defects in material and workmanship for a period of eighteen (18) months from the date of shipment or twelve (12) months from the date of installation whichever comes first. This warranty is limited to the repair or replacement of the defective item providing that it was handled, installed, used and maintained in accordance with the manufacturer's recommendations and applicable standard industry practices. HAITIMA will not be liable for any additional direct or indirect costs beyond the repair or replacement of the defective item.

This warranty is in lieu of any other warranty expressed or implied.

### 6.2 SERVICE

Manufacturer may provide field installation and debugging where contractually specified.

Manufacturer will follow up the quality of the valve provided and offer service in accordance with customer requirements.

VZBE...T-63-E-3.../8068829/1701

		<b>3-Way Ball Valve 2057ND 1000 WOG</b>		<b>Version</b>	<b>A</b>
				Date	Apr.20,2013
Document No.	HIM-130			Page	10

## 7. TECHNICAL PARAMETERS AND VALVE STRUCTURE

### 7.1 SPECIFICATION LIST

Type	2057ND
Technical Parameters	
Nominal pressure	1000 WOG
Working temperature	-20°C ~ 200°C, (-4°F ~ 392°F)
Medium	Water, Steam, Oxygen, Vacuum, Chemical, Oil, Food Processing
Pressure test	API 598

Table 2 - Specification List

### 7.2 TORQUE

NPS	DN	Breaking torque		Stem Nut	
		N-m	in-lb	N-m	in-lb
1/4"	8	9.6	85.1	4.9	43.4
3/8"	10	9.6	85.1	4.9	43.4
1/2"	15	9.6	85.1	6.4	56.6
3/4"	20	19.2	170.3	6.4	56.6
1"	25	25.2	223.2	9.8	86.7
1-1/4"	32	33	292.3	9.8	86.7
1-1/2"	40	45.5	402.7	11.8	104.4
2"	50	110.5	978	11.8	104.4

Table 3 – Torque

VZBE...T-63-E-3.../8068829/1701



### 3-Way Ball Valve 2057ND 1000 WOG

**Version**

**A**

Date

Apr.20,2013

Document No.

HIM-130

Page

11

## 7.3 PRESSURE-TEMPERATURE RATINGS

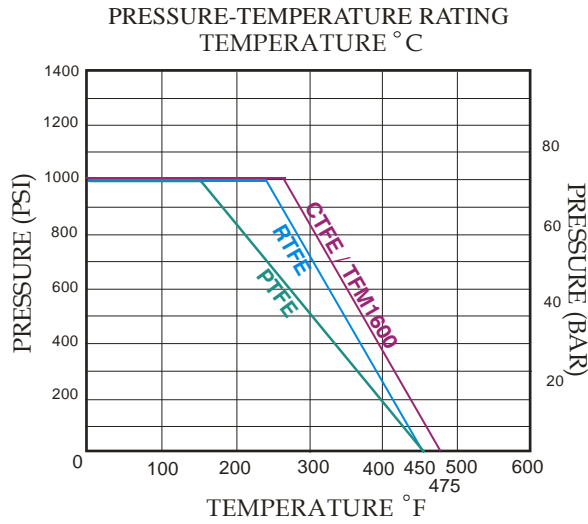

Table 4 - Pressure-Temperature Ratings

## 7.4 VALVE STRUCTURE

Please refer to drawings for each type of valve structure, main parts, materials and dimensions.