

Abdeckkappe VAMC-S6-CH/-CS

FESTO

Festo AG & Co. KG

Postfach
73726 Esslingen
Deutschland
+49 711 347-0
www.festo.com

1. Teileliste



- 1 Abdeckkappe (10x)
VAMC-S6-CH
- 2 Abdeckkappe (10x)
VAMC-S6-CS

Nicht im Lieferumfang:
3 Magnetventil (1x)
z. B. VSVA-...-1T1L/-2AT1L

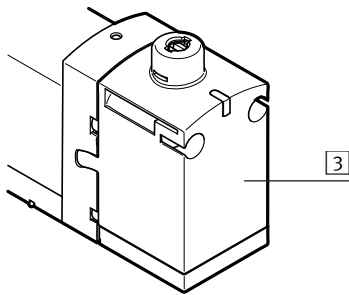

2. Bestimmungsgemäße Verwendung

Abdeckkappe VAMC-S6-CH:
Manuelle tastende Betätigung des Magnetventils 3.

Abdeckkappe VAMC-S6-CS:
Sperrung der manuellen Betätigung des Magnetventils 3.

3. Hinweise zur Montage

→ Hinweis

Funktionsstörung durch unsachgemäße Montage.

- Druckluft vor Montagearbeiten abschalten.
- Handhilfsbetätigung (A) vor der Montage auf **unbetätigt** stellen.



4. Montage

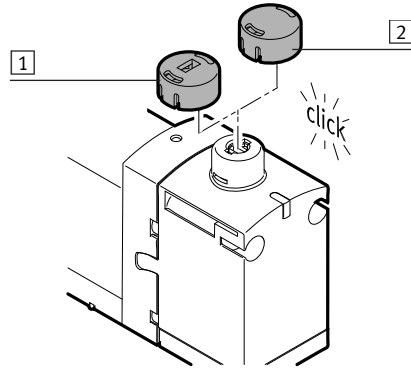

- Abdeckkappe 1/2 wie dargestellt montieren (→ Hinweis).

5. Betätigung

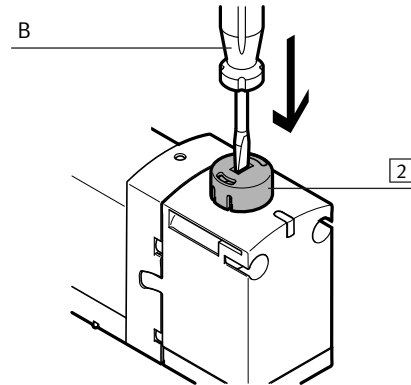

- Schraubendreher (B) in Pfeilrichtung bewegen.

Cover cap VAMC-S6-CH/-CS

FESTO

Festo AG & Co. KG

Postfach
73726 Esslingen
Germany
+49 711 347-0
www.festo.com

1. Parts list



- 1 Cover cap (10x)
VAMC-S6-CH
- 2 Cover cap (10x)
VAMC-S6-CS

Not in scope of delivery:

- 3 Solenoid valve (1x)
e. g. VSVA-...-1T1L/-2AT1L

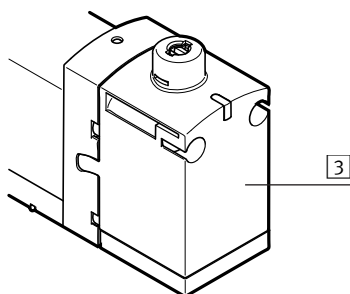

2. Intended use

Cover cap VAMC-S6-CH:

Manual non-detenting actuation of the solenoid valve 3.

Cover cap VAMC-S6-CS:

Blocks manual actuation of the solenoid valve 3.

3. Notes on mounting

→ Note

Malfunction due to incorrect mounting.

- Switch off compressed air before mounting work.
- Set manual override (A) to **unactuated** prior to mounting.

A



unactuated



actuated

4. Mounting

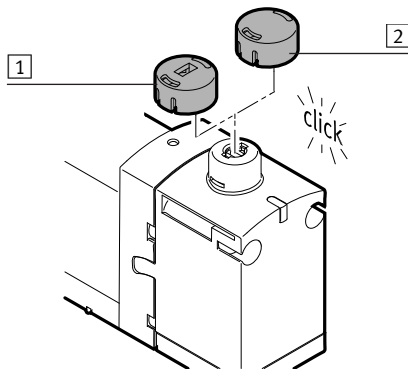

- Mount cover cap 1/2 as shown (→ Note).

5. Actuation

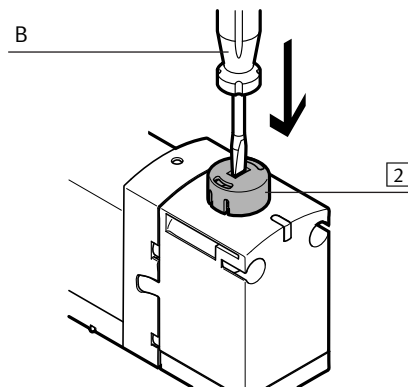

- Turn screwdriver (B) in the direction of the arrow.