

FESTO

Festo AG & Co. KG

Postfach
D-73726 Esslingen
++49/(0)711/347-0
www.festo.com

Manometerbausatz MS9-AG-... MS9-A4

Bestimmungsgemäß dient der Manometerbausatz MS9-AG-... zur Befestigung des beigelegten Manometers [2] am Wartungsgerät. Bestimmungsgemäß dient der Manometerbausatz MS9-A4 zur Befestigung des Manometers [15] am Wartungsgerät.

1. Teileliste

1a. Manometerbausatz MS9-AG-...

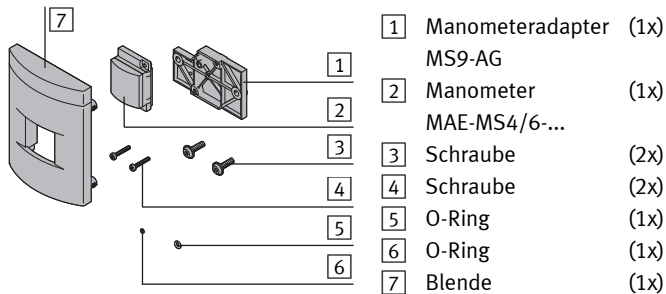

1b. Manometerbausatz MS9-A4

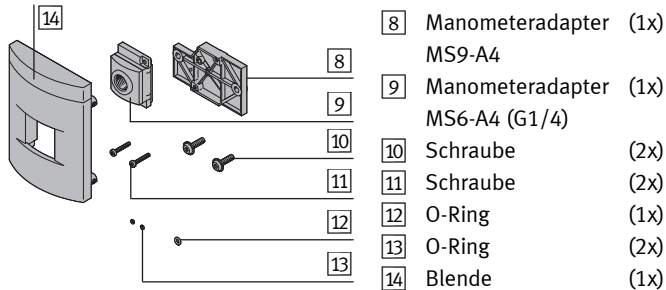

1c. Manometer [15]

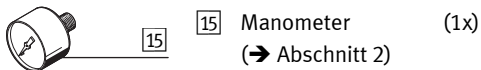

2. Zulässige Manometer [15]

2a. Manometeradapter [9] MS6-A4 (G1/4)

Manometer [15]	Gewinde	Dichtsystem
MA-...R1/4-...	R1/4	D1, D2
MA-...G1/4-...	G1/4	D3, D4

2b. Dichtsysteme

Dichtsystem	Gewindearten des Manometers [15]
D1	Kegelförmiges R-Gewinde mit PTFE-Gewindedichtbeschichtung
D2	Kegelförmiges R-Gewinde mit PTFE-Dichtband (Nicht im Lieferumfang)
D3	Zylindrisches Gewinde mit vormontiertem Axialdichtring (Polymer)
D4	Zylindrisches Gewinde mit anwenderspezifischem Axialdichtring (Nicht im Lieferumfang)

3. Demontage

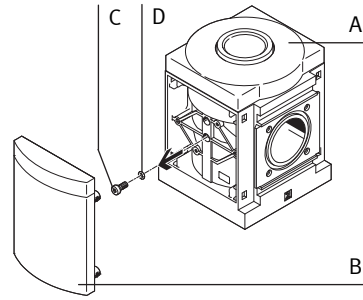

- Entfernen Sie die Blende (B), den Nippel (C) und den O-Ring (D) vom Wartungsgerät (A).

4. Montage

4a. Manometerbausatz MS9-AG-...

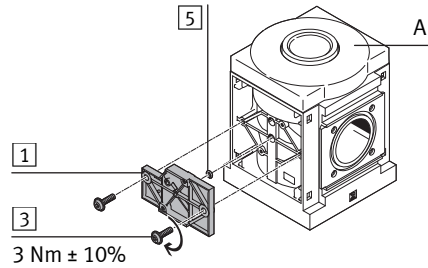

- Montieren Sie den Manometeradapter [1] und den O-Ring [5]¹⁾ am Wartungsgerät (A).
- Halten Sie das zulässige Anziehdrehmoment M_A der Schrauben [3] ein.

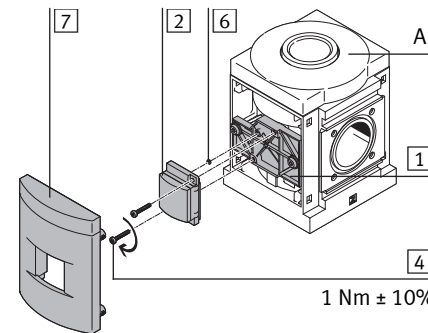

- Montieren Sie das Manometer [2] und den O-Ring [6] am Manometeradapter [1].
- Halten Sie das zulässige Anziehdrehmoment M_A der Schrauben [4] ein.
- Befestigen Sie die Blende [7] am Wartungsgerät (A).

4b. Manometerbausatz MS9-A4

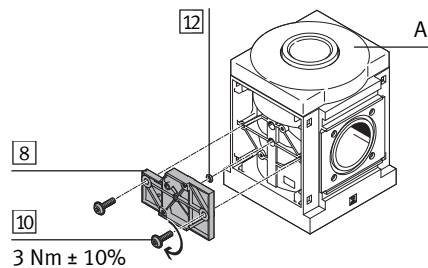

- Montieren Sie den Manometeradapter [8] und den O-Ring [12]¹⁾ am Wartungsgerät (A).
- Halten Sie das zulässige Anziehdrehmoment M_A der Schrauben [10] ein.

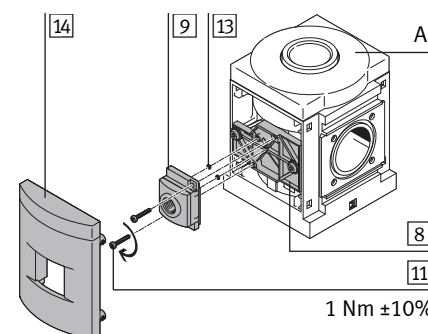

- Montieren Sie den Manometeradapter [9] und die O-Ringe [13] am Manometeradapter [8].
- Halten Sie das zulässige Anziehdrehmoment M_A der Schrauben [11] ein.
- Befestigen Sie die Blende [14] am Wartungsgerät (A).

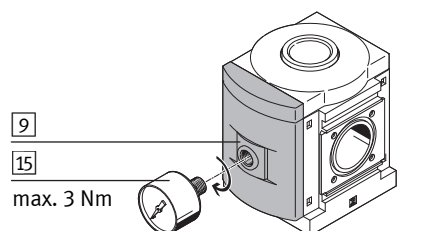

- Beachten Sie das für Ihren Fall zutreffende Dichtsystem (→ Abschnitt 2).
- Drehen Sie das Manometer [15] soweit in den Manometeradapter [9], dass keine Leckage entsteht. Beachten Sie das angegebene Anziehdrehmoment.

¹⁾ Um die Montage zu erleichtern, fetten Sie den O-Ring [5]/[12] mit LUB-KB1 silikonfrei von Festo.

FESTO

Festo AG & Co. KG

Postfach
D-73726 Esslingen
++49/(0)711/347-0
www.festo.com

Pressure gauge kit MS9-AG-... MS9-A4

The pressure gauge kit MS9-AG-... is intended for mounting the accompanying pressure gauge [2] on the service unit.
The pressure gauge kit MS9-A4 is intended for mounting the pressure gauge [15] on the service unit.

1. Parts list

1a. Pressure gauge kit MS9-AG-...

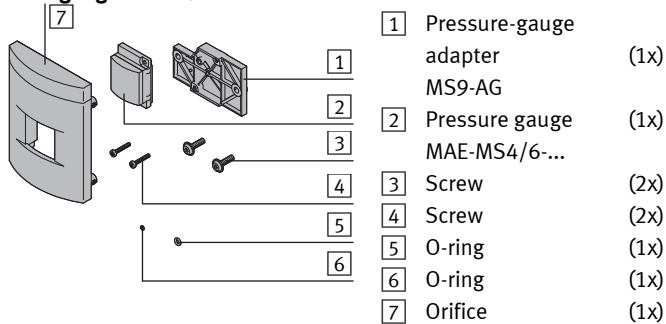

1b. Pressure gauge kit MS9-A4

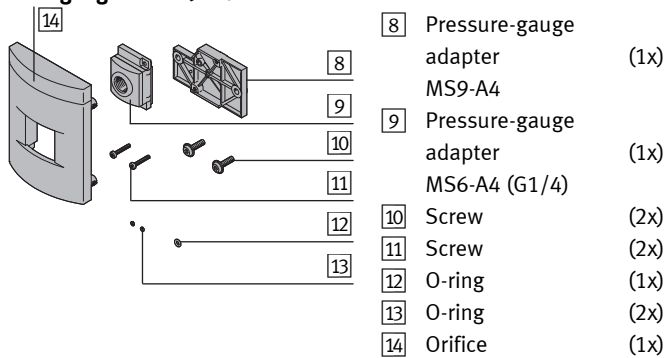

1c. Pressure gauge [15]

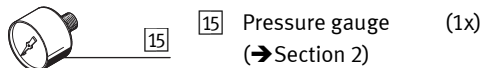

2. Permissible pressure gauges [15]

2a. Pressure-gauge adapter [9] MS6-A4 (G1/4)

Pressure gauge [15]	Thread	Sealing system
MA-...R1/4...	R1/4	D1, D2
MA-...G1/4...	G1/4	D3, D4

2b. Sealing systems

Sealing system	Thread types of the pressure gauge [15]
D1	Conical R-thread with PTFE thread sealing coating
D2	Conical R-thread with PTFE sealing tape (not included in the scope of delivery)
D3	Cylindrical thread with pre-fitted axial sealing ring (polymer)
D4	Cylindrical thread with user-specific axial sealing ring (not included in the scope of delivery)

3. Disassembly

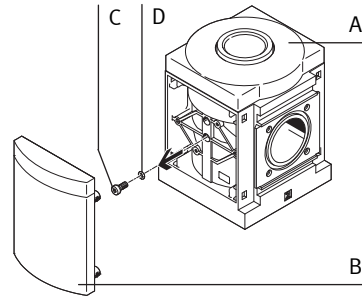

- Remove the cover (B), nipple (C) and the O-ring (D) from the service unit (A).

4. Assembly

4a. Pressure gauge kit MS9-AG-...

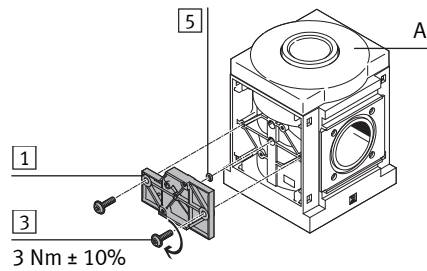

- Mount the pressure-gauge adapter [1] and the O-ring [5]¹⁾ on the service unit (A).
- Observe the permitted tightening torque M_A of the screws [3].

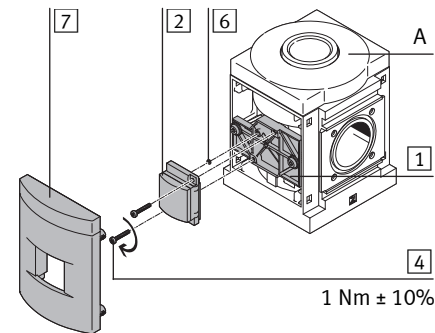

- Mount the pressure gauge [2] and the O-ring [6] on the pressure-gauge adapter [1].
- Maintain the permissible torque M_A of the screws [4].
- Fasten the cover [7] to the service unit (A).

4b. Pressure gauge kit MS9-A4

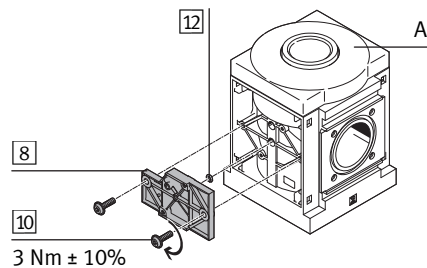

- Mount the pressure-gauge adapter [8] and the O-ring [12]¹⁾ on the service unit (A).
- Maintain the permissible torque M_A of the screws [10].

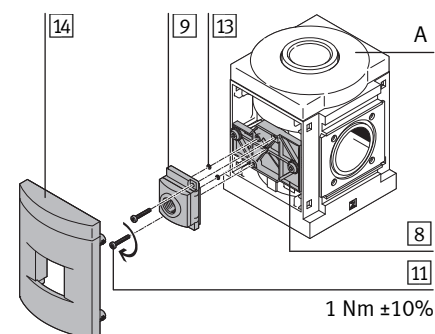

- Mount the pressure-gauge adapter [9] and the O-ring [13] on the pressure-gauge adapter [8].
- Maintain the permissible torque M_A of the screws [11].
- Fasten the cover [14] to the service unit (A).

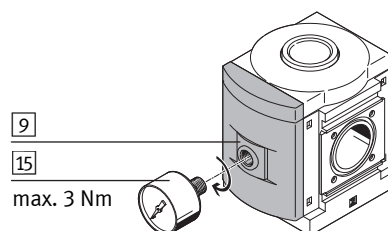

- Observe the sealing system applicable for your application (→ Section 2).
- Screw the pressure gauge [15] into the pressure-gauge adapter [9] until there is no leakage. Observe the specified tightening torque.

¹⁾ To make mounting easier, grease the O-ring [5]/[12] with silicone-free LUB-KB1 from Festo.